

INDOOR UNIT PARTS CATALOG

**No. OBB589
REVISED EDITION-F**

Models

MSZ-EF18VEW/B/S - E1	MSZ-EF22VEW/B/S - E1	MSZ-EF25VEW/B/S - E1
MSZ-EF35VEW/B/S - E1	MSZ-EF42VEW/B/S - E1	MSZ-EF50VEW/B/S - E1
MSZ-EF18VE2W/B/S - E1	MSZ-EF22VE2W/B/S - E1	MSZ-EF25VE2W/B/S - E1
MSZ-EF35VE2W/B/S - E1	MSZ-EF42VE2W/B/S - E1	MSZ-EF50VE2W/B/S - E1
MSZ-EF18VE2W/B/S - ER1	MSZ-EF22VE2W/B/S - ER1	MSZ-EF25VE2W/B/S - ER1
MSZ-EF35VE2W/B/S - ER1	MSZ-EF42VE2W/B/S - ER1	MSZ-EF50VE2W/B/S - ER1
MSZ-EF18VE3W/B/S - E1 , E2	MSZ-EF22VE3W/B/S - E1 , E2	MSZ-EF25VE3W/B/S - E1 , E2
MSZ-EF35VE3W/B/S - E1 , E2	MSZ-EF42VE3W/B/S - E1 , E2	MSZ-EF50VE3W/B/S - E1 , E2
MSZ-EF35VE3W/B/S - ER1 , ER2	MSZ-EF22VE3W/B/S - ER1 , ER2	MSZ-EF25VE3W/B/S - ER1 , ER2
MSZ-EF42VE3W/B/S - ER1 , ER2	MSZ-EF50VE3W/B/S - ER1 , ER2	

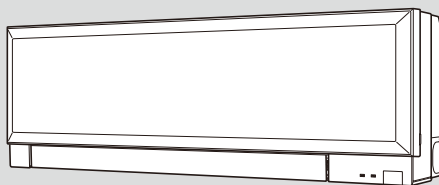

MSZ-EF·VEW
MSZ-EF·VEB
MSZ-EF·VES



CONTENTS

1. SERVICE PARTS LIST	2
2. OPTIONAL PARTS	35

SERVICE MANUAL (OBH589)

Revision A:

- Part numbers of the electronic control P.C. boards have been changed.

Revision B:

- MSZ-EF18VEW - [E1], MSZ-EF18VEB - [E1] and MSZ-EF18VES - [E1] have been added.

Revision C:

- MSZ-EF18/22/25/35/42/50VE2W - [E1], [ER1], MSZ-EF18/22/25/35/42/50VE2B - [E1], [ER1] and MSZ-EF18/22/25/35/42/50VE2S - [E1], [ER1] have been added.

Revision D:

- MSZ-EF18/22/25/35/42/50VE3W - [E1], MSZ-EF18/22/25/35/42/50VE3B - [E1], MSZ-EF18/22/25/35/42/50VE3S - [E1], MSZ-EF22/25/35/42/50VE3W - [ER1], MSZ-EF22/25/35/42/50VE3B - [ER1] and MSZ-EF22/25/35/42/50VE3S - [ER1] have been added.

Revision E:

- MSZ-EF18/22/25/35/42/50VE3W - [E2], MSZ-EF22/25/35/42/50VE3W - [ER2], MSZ-EF18/22/25/35/42/50VE3B - [E2], MSZ-EF22/25/35/42/50VE3B - [ER2], MSZ-EF18/22/25/35/42/50VE3S - [E2] and MSZ-EF22/25/35/42/50VE3S - [ER2] have been added.

Revision F:

- Some descriptions have been modified.

1 SERVICE PARTS LIST

MSZ-EF18VEW MSZ-EF22VEW MSZ-EF25VEW MSZ-EF35VEW MSZ-EF42VEW MSZ-EF50VEW
MSZ-EF18VEB MSZ-EF22VEB MSZ-EF25VEB MSZ-EF35VEB MSZ-EF42VEB MSZ-EF50VEB
MSZ-EF18VES MSZ-EF22VES MSZ-EF25VES MSZ-EF35VES MSZ-EF42VES MSZ-EF50VES
1-1. INDOOR UNIT STRUCTURAL PARTS

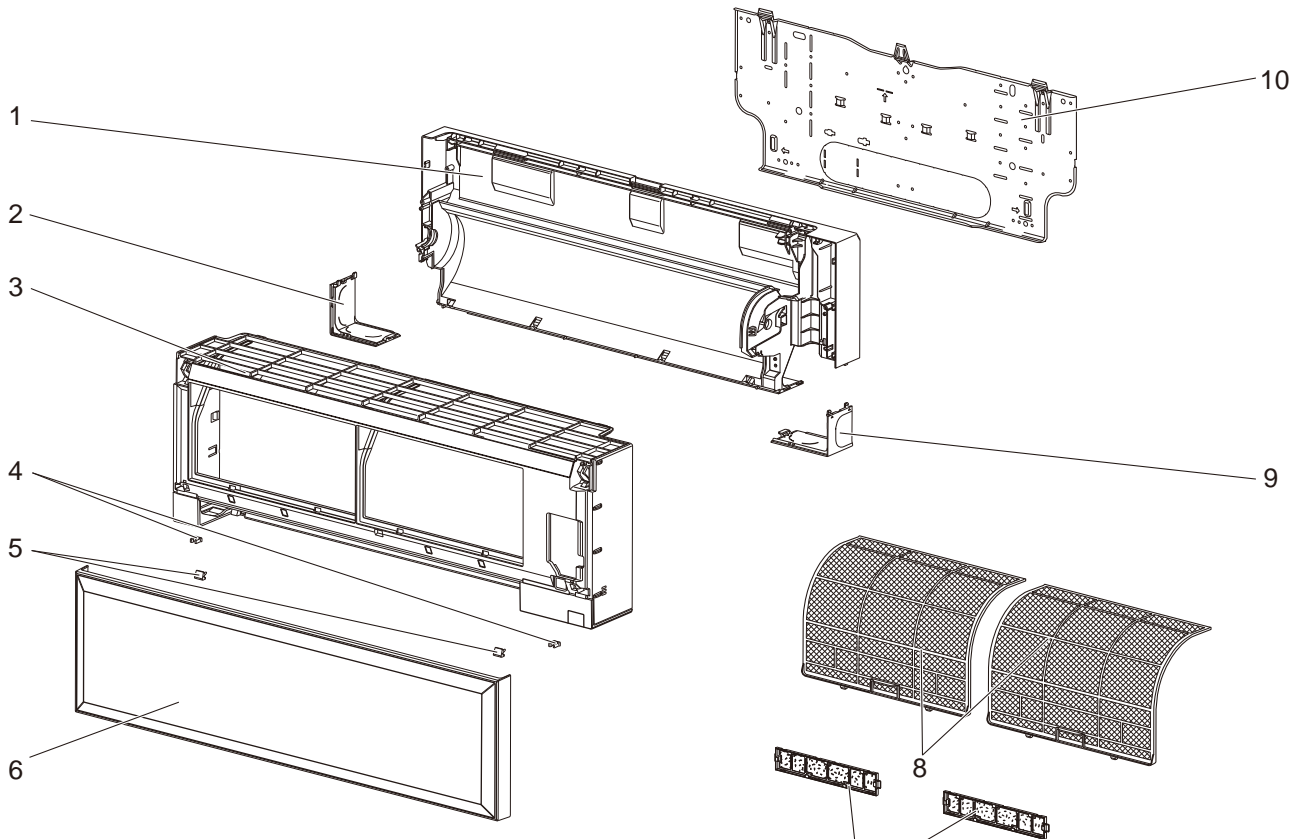

1-2. ACCESSORY AND REMOTE CONTROLLER

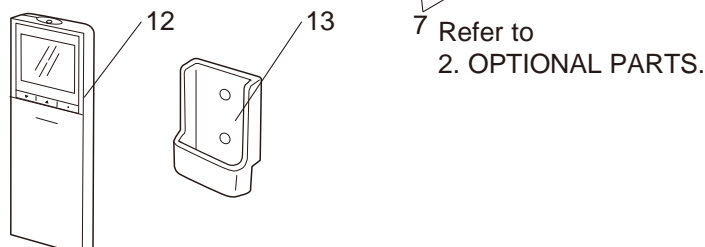

1-1. INDOOR UNIT STRUCTURAL PARTS

Part numbers that is circled is not shown in the illustration.

No.	Part No.	Part name	Symbol in Wiring Diagram	Q'ty/unit																		Remarks
				MSZ-EF																		
				18			22			25			35			42			50			
VEW	VEB	VES	VEW	VEB	VES	VEW	VEB	VES	VEW	VEB	VES	VEW	VEB	VES	VEW	VEB	VES					
-E1	-E1	-E1	-E1	-E1	-E1	-E1	-E1	-E1	-E1	-E1	-E1	-E1	-E1	-E1	-E1	-E1	-E1					
1	E12 F95 234	BOX ASSEMBLY		1		1		1		1		1		1		1		1				
	E12 G21 234	BOX ASSEMBLY			1		1		1		1		1		1		1					
	E12 G26 234	BOX ASSEMBLY				1		1		1		1		1		1		1				
2	E12 F95 976	CORNER BOX LEFT		1		1		1		1		1		1		1		1				
	E12 G21 976	CORNER BOX LEFT			1		1		1		1		1		1		1					
	E12 G26 976	CORNER BOX LEFT				1		1		1		1		1		1		1				
3	E12 F95 000	PANEL ASSEMBLY		1		1		1		1		1		1		1		1	Includes No. 4, 5, and 6			
	E12 G21 000	PANEL ASSEMBLY			1		1		1		1		1		1		1		Includes No. 4, 5, and 6			
	E12 G26 000	PANEL ASSEMBLY				1		1		1		1		1		1		1	Includes No. 4, 5, and 6			
4	E12 F95 142	CATCH		2	2	2	2	2	2	2	2	2	2	2	2	2	2	2	2 PCS/SET			
5	E12 F95 067	SCREW CAP		2		2		2		2		2		2		2		2	2 PCS/SET			
	E12 G21 067	SCREW CAP			2		2		2		2		2		2		2		2 PCS/SET			
	E12 G26 067	SCREW CAP				2		2		2		2		2		2		2	2 PCS/SET			
6	E12 F95 010	FRONT PANEL		1		1		1		1		1		1		1		1				
	E12 G21 010	FRONT PANEL			1		1		1		1		1		1		1					
	E12 G26 010	FRONT PANEL				1		1		1		1		1		1		1				
7	—	AIR CLEANING FILTER		2	2	2	2	2	2	2	2	2	2	2	2	2	2	2	1 PC/SET			
8	E12 F95 100	NANO PLATINUM FILTER		2	2	2	2	2	2	2	2	2	2	2	2	2	2	2	1 PC/SET			
9	E12 F95 975	CORNER BOX RIGHT		1		1		1		1		1		1		1		1				
	E12 G21 975	CORNER BOX RIGHT			1		1		1		1		1		1		1					
	E12 G26 975	CORNER BOX RIGHT				1		1		1		1		1		1		1				
10	E12 F95 970	INSTALLATION PLATE		1	1	1	1	1	1	1	1	1	1	1	1	1	1	1				
⑪	—	SOFT DRY CLOTH		1		1		1		1		1		1		1		1	MAC-1001CL-E			

1-2. ACCESSORY AND REMOTE CONTROLLER

No.	Part No.	Part name	Symbol in Wiring Diagram	Q'ty/unit																		Remarks
				MSZ-EF																		
				18			22			25			35			42			50			
VEW	VEB	VES	VEW	VEB	VES	VEW	VEB	VES	VEW	VEB	VES	VEW	VEB	VES	VEW	VEB	VES					
-E1	-E1	-E1	-E1	-E1	-E1	-E1	-E1	-E1	-E1	-E1	-E1	-E1	-E1	-E1	-E1	-E1	-E1					
12	E12 F95 426	REMOTE CONTROLLER		1	1	1	1	1	1	1	1	1	1	1	1	1	1	1	SG11D			
13	E12 F28 083	REMOTE CONTROLLER HOLDER		1	1	1	1	1	1	1	1	1	1	1	1	1	1	1				

MSZ-EF18VEW MSZ-EF22VEW MSZ-EF25VEW MSZ-EF35VEW MSZ-EF42VEW MSZ-EF50VEW
 MSZ-EF18VEB MSZ-EF22VEB MSZ-EF25VEB MSZ-EF35VEB MSZ-EF42VEB MSZ-EF50VEB
 MSZ-EF18VES MSZ-EF22VES MSZ-EF25VES MSZ-EF35VES MSZ-EF42VES MSZ-EF50VES

1-3. INDOOR UNIT ELECTRICAL PARTS AND FUNCTIONAL PARTS

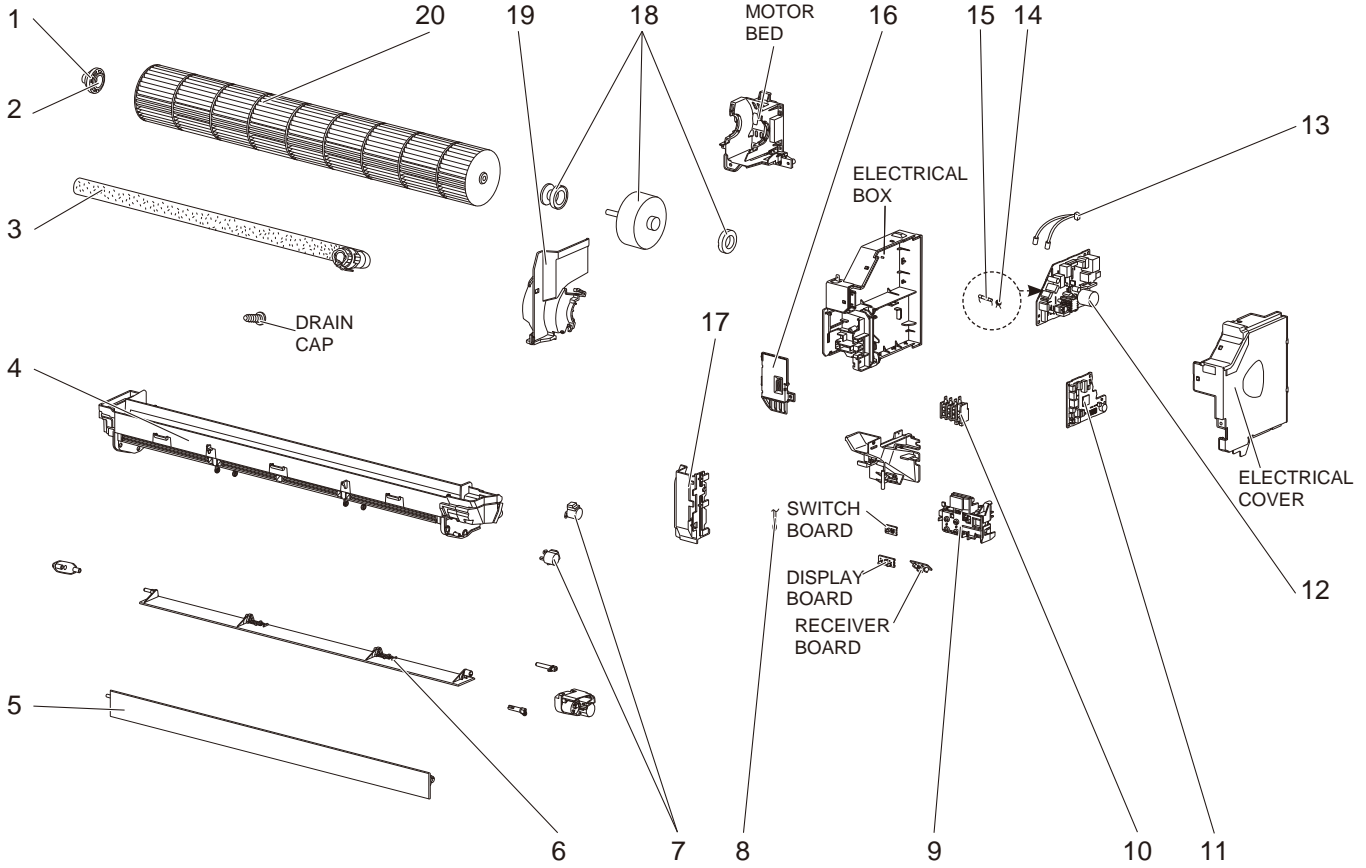

1-4. INDOOR UNIT HEAT EXCHANGER

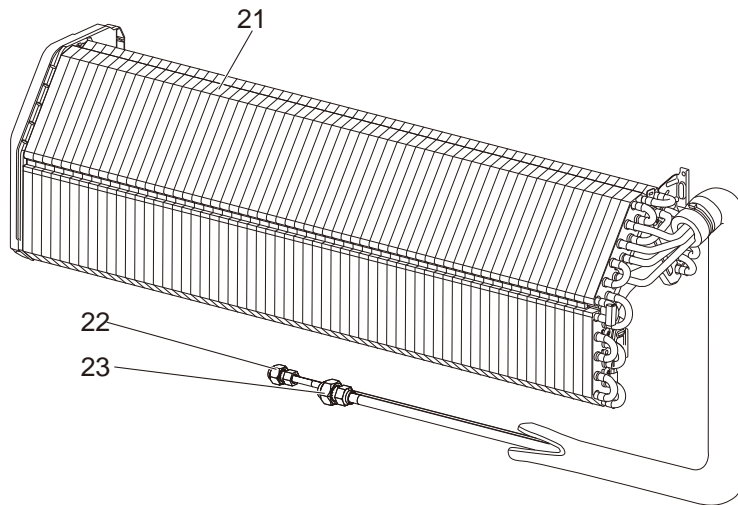

1-3. INDOOR UNIT ELECTRICAL PARTS AND FUNCTIONAL PARTS

No.	Part No.	Part name	Symbol in Wiring Diagram	Q'ty/unit																		Remarks
				MSZ-EF																		
				18			22			25			35			42			50			
VEW	VEB	VES	VEW	VEB	VES	VEW	VEB	VES	VEW	VEB	VES	VEW	VEB	VES	VEW	VEB	VES	VEW	VEB	VES		
-E1	-E1	-E1	-E1	-E1	-E1	-E1	-E1	-E1	-E1	-E1	-E1	-E1	-E1	-E1	-E1	-E1	-E1	-E1	-E1	-E1		
1	E12 751 509	BEARING MOUNT		1	1	1	1	1	1	1	1	1	1	1	1	1	1	1	1	1	1	
2	E12 001 504	SLEEVE BEARING		1	1	1	1	1	1	1	1	1	1	1	1	1	1	1	1	1	1	
3	E12 897 702	DRAIN HOSE		1	1	1	1	1	1	1	1	1	1	1	1	1	1	1	1	1	1	
4	E12 F95 235	NOZZLE ASSEMBLY		1			1			1			1			1			1			
	E12 G21 235	NOZZLE ASSEMBLY			1			1			1			1			1			1		
	E12 G26 235	NOZZLE ASSEMBLY				1			1			1			1			1			1	
5	E12 F95 040	VANE UPPER		1			1			1			1			1			1			
	E12 G21 040	VANE UPPER			1			1			1			1			1			1		
	E12 G26 040	VANE UPPER				1			1			1			1			1			1	
6	E12 F95 041	VANE LOWER		1			1			1			1			1			1			
	E12 G21 041	VANE LOWER			1			1			1			1			1			1		
	E12 G26 041	VANE LOWER				1			1			1			1			1			1	
7	E12 A89 303	VANE MOTOR	MV	2	2	2	2	2	2	2	2	2	2	2	2	2	2	2	2	2	2	UP & DOWN, 1 PC/SET
8	E12 F95 308	ROOM TEMPERATURE THERMISTOR	RT11	1	1	1	1	1	1	1	1	1	1	1	1	1	1	1	1	1	1	
9	E12 F95 095	DISPLAY P.C. BOARD HOLDER		1	1	1	1	1	1	1	1	1	1	1	1	1	1	1	1	1	1	
10	E12 F95 375	TERMINAL BLOCK	TB	1	1	1	1	1	1	1	1	1	1	1	1	1	1	1	1	1	1	
11	E12 F95 452	ELECTRONIC CONTROL P.C. BOARD		1	1	1	1	1	1													Includes RECEIVER BOARD, DISPLAY BOARD and SWITCH BOARD.
	E12 G22 452	ELECTRONIC CONTROL P.C. BOARD								1	1	1										
	E12 G23 452	ELECTRONIC CONTROL P.C. BOARD											1	1	1							
	E12 G24 452	ELECTRONIC CONTROL P.C. BOARD														1	1	1				
	E12 G25 452	ELECTRONIC CONTROL P.C. BOARD																	1	1	1	
12	E12 F98 440	POWER P.C. BOARD		1	1	1	1	1	1	1	1	1	1	1	1	1	1	1	1	1	1	
13	E12 F95 307	INDOOR COIL THERMISTOR	RT12,RT13	1	1	1	1	1	1	1	1	1	1	1	1	1	1	1	1	1	1	
14	E12 B75 385	VARISTOR	NR11	1	1	1	1	1	1	1	1	1	1	1	1	1	1	1	1	1	1	
15	E12 A49 382	FUSE	F11	1	1	1	1	1	1	1	1	1	1	1	1	1	1	1	1	1	1	T3.15AL250V
16	E12 F95 784	V.A. CLAMP		1	1	1	1	1	1	1	1	1	1	1	1	1	1	1	1	1	1	
17	E12 F95 541	WATER CUT		1	1	1	1	1	1	1	1	1	1	1	1	1	1	1	1	1	1	
18	E12 F95 300	INDOOR FAN MOTOR	MF	1	1	1	1	1	1	1	1	1	1	1	1	1	1	1	1	1	1	RC0J40-□□ Includes FAN MOTOR RUBBER MOUNT (2 PC/SET)
19	E12 F95 333	MOTOR BAND		1	1	1	1	1	1	1	1	1	1	1	1	1	1	1	1	1	1	
20	E12 F95 302	LINE FLOW FAN		1	1	1	1	1	1	1	1	1	1	1	1	1	1	1	1	1	1	

1-4. INDOOR UNIT HEAT EXCHANGER

No.	Part No.	Part name	Symbol in Wiring Diagram	Q'ty/unit																		Remarks
				MSZ-EF																		
				18			22			25			35			42			50			
VEW	VEB	VES	VEW	VEB	VES	VEW	VEB	VES	VEW	VEB	VES	VEW	VEB	VES	VEW	VEB	VES	VEW	VEB	VES		
-E1	-E1	-E1	-E1	-E1	-E1	-E1	-E1	-E1	-E1	-E1	-E1	-E1	-E1	-E1	-E1	-E1	-E1	-E1	-E1	-E1		
21	E12 F95 620	INDOOR HEAT EXCHANGER		1	1	1	1	1	1	1	1	1	1	1	1	1	1	1	1	1	1	
	E12 F99 620	INDOOR HEAT EXCHANGER																	1	1	1	
22	E12 151 667	UNION (LIQUID)		1	1	1	1	1	1	1	1	1	1	1	1	1	1	1	1	1	1	ø6.35
23	E12 815 666	UNION (GAS)		1	1	1	1	1	1	1	1	1	1	1	1	1	1	1	1	1	1	ø9.52
	E12 155 666	UNION (GAS)																	1	1	1	ø12.7

MSZ-EF18VE2W -E1 MSZ-EF22VE2W -E1 MSZ-EF25VE2W -E1
MSZ-EF18VE2B -E1 MSZ-EF22VE2B -E1 MSZ-EF25VE2B -E1
MSZ-EF18VE2S -E1 MSZ-EF22VE2S -E1 MSZ-EF25VE2S -E1
MSZ-EF35VE2W -E1 MSZ-EF42VE2W -E1 MSZ-EF50VE2W -E1
MSZ-EF35VE2B -E1 MSZ-EF42VE2B -E1 MSZ-EF50VE2B -E1
MSZ-EF35VE2S -E1 MSZ-EF42VE2S -E1 MSZ-EF50VE2S -E1

1-5. INDOOR UNIT STRUCTURAL PARTS

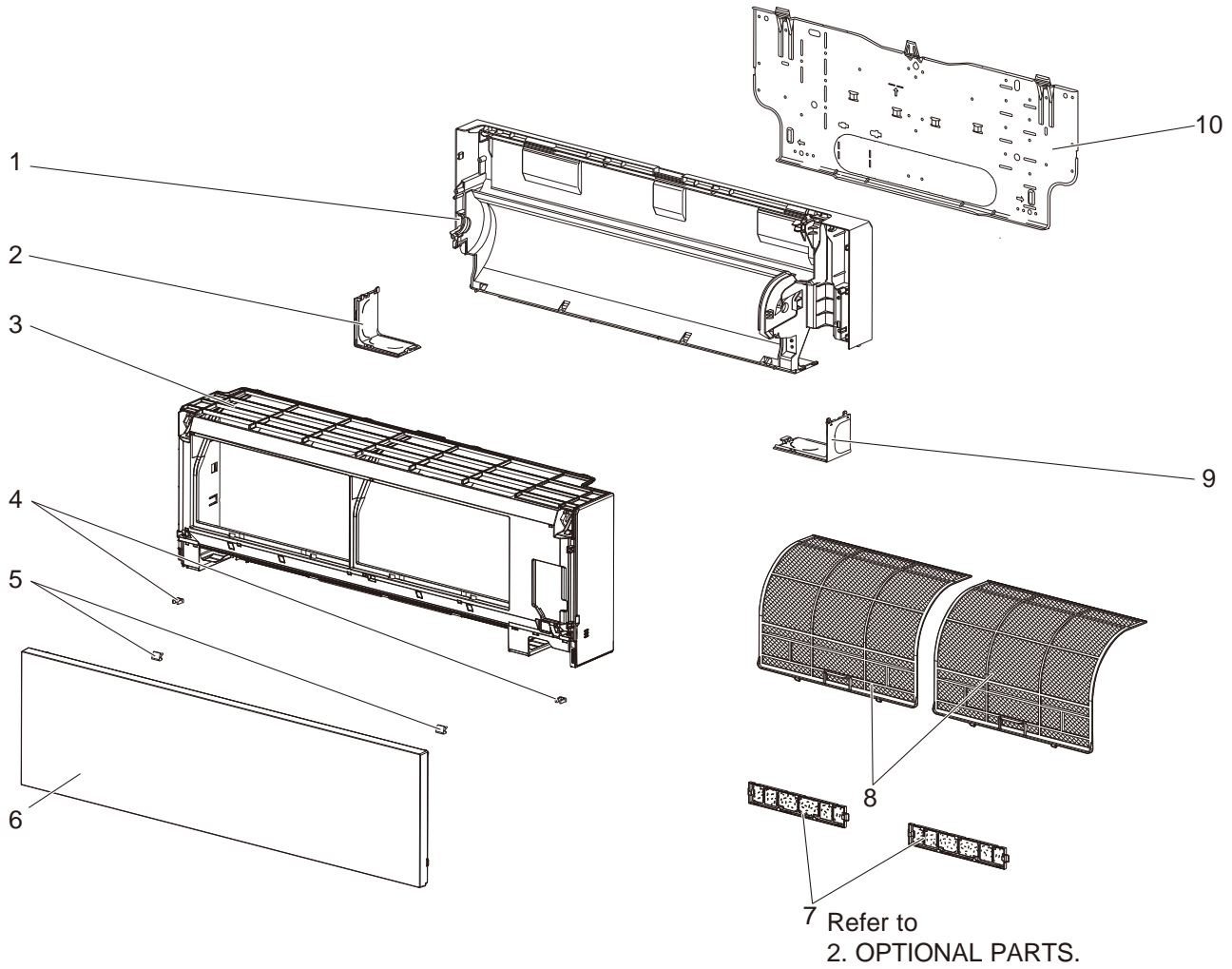

1-6. ACCESSORY AND REMOTE CONTROLLER

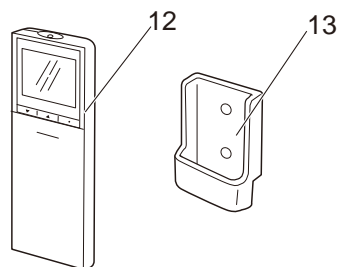

1-5. INDOOR UNIT STRUCTURAL PARTS

Part numbers that is circled is not shown in the illustration.

No.	Part No.	Part name	Symbol in Wiring Diagram	Q'ty/unit																		Remarks
				MSZ-EF																		
				18			22			25			35			42			50			
				VE2W -E1	VE2B -E1	VE2S -E1	VE2W -E1	VE2B -E1	VE2S -E1	VE2W -E1	VE2B -E1	VE2S -E1	VE2W -E1	VE2B -E1	VE2S -E1	VE2W -E1	VE2B -E1	VE2S -E1	VE2W -E1	VE2B -E1	VE2S -E1	
1	E12 F95 234	BOX ASSEMBLY		1			1			1			1			1			1			
	E12 G21 234	BOX ASSEMBLY			1			1			1			1			1			1		
	E12 G26 234	BOX ASSEMBLY				1			1			1			1			1			1	
2	E12 F95 976	CORNER BOX LEFT		1			1			1			1			1			1			
	E12 G21 976	CORNER BOX LEFT			1			1			1			1			1			1		
	E12 G26 976	CORNER BOX LEFT				1			1			1			1			1			1	
3	E12 M42 000	PANEL ASSEMBLY		1			1			1			1			1			1			Includes No. 4, 5, and 6
	E12 M38 000	PANEL ASSEMBLY			1			1			1			1			1			1		Includes No. 4, 5, and 6
	E12 M40 000	PANEL ASSEMBLY				1			1			1			1			1			1	Includes No. 4, 5, and 6
4	E12 F95 142	CATCH		2	2	2	2	2	2	2	2	2	2	2	2	2	2	2	2	2	2	2 PCS/SET
5	E12 F95 067	SCREW CAP		2			2			2			2			2			2			2 PCS/SET
	E12 G21 067	SCREW CAP			2			2			2			2			2			2		2 PCS/SET
	E12 G26 067	SCREW CAP				2			2			2			2			2			2	2 PCS/SET
6	E12 M42 010	FRONT PANEL		1			1			1			1			1			1			
	E12 M38 010	FRONT PANEL			1			1			1			1			1			1		
	E12 M40 010	FRONT PANEL				1			1			1			1			1			1	
7	—	AIR CLEANING FILTER		2	2	2	2	2	2	2	2	2	2	2	2	2	2	2	2	2	2	1 PC/SET
8	E12 F95 100	NANO PLATINUM FILTER		2	2	2	2	2	2	2	2	2	2	2	2	2	2	2	2	2	2	1 PC/SET
9	E12 F95 975	CORNER BOX RIGHT		1			1			1			1			1			1			
	E12 G21 975	CORNER BOX RIGHT			1			1			1			1			1			1		
	E12 G26 975	CORNER BOX RIGHT				1			1			1			1			1			1	
10	E12 F95 970	INSTALLATION PLATE		1	1	1	1	1	1	1	1	1	1	1	1	1	1	1	1	1	1	
⑪	—	SOFT DRY CLOTH				1			1			1			1			1			1	MAC- 1001CL-E

1-6. ACCESSORY AND REMOTE CONTROLLER

No.	Part No.	Part name	Symbol in Wiring Diagram	Q'ty/unit																		Remarks
				MSZ-EF																		
				18			22			25			35			42			50			
				VE2W -E1	VE2B -E1	VE2S -E1	VE2W -E1	VE2B -E1	VE2S -E1	VE2W -E1	VE2B -E1	VE2S -E1	VE2W -E1	VE2B -E1	VE2S -E1	VE2W -E1	VE2B -E1	VE2S -E1	VE2W -E1	VE2B -E1	VE2S -E1	
12	E12 M42 426	REMOTE CONTROLLER		1	1	1	1	1	1	1	1	1	1	1	1	1	1	1	1	1	1	SG14D
13	E12 F28 083	REMOTE CONTROLLER HOLDER		1	1	1	1	1	1	1	1	1	1	1	1	1	1	1	1	1	1	

MSZ-EF18VE2W -E1 MSZ-EF22VE2W -E1 MSZ-EF25VE2W -E1
MSZ-EF18VE2B -E1 MSZ-EF22VE2B -E1 MSZ-EF25VE2B -E1
MSZ-EF18VE2S -E1 MSZ-EF22VE2S -E1 MSZ-EF25VE2S -E1
MSZ-EF35VE2W -E1 MSZ-EF42VE2W -E1 MSZ-EF50VE2W -E1
MSZ-EF35VE2B -E1 MSZ-EF42VE2B -E1 MSZ-EF50VE2B -E1
MSZ-EF35VE2S -E1 MSZ-EF42VE2S -E1 MSZ-EF50VE2S -E1

1-7. INDOOR UNIT ELECTRICAL PARTS AND FUNCTIONAL PARTS

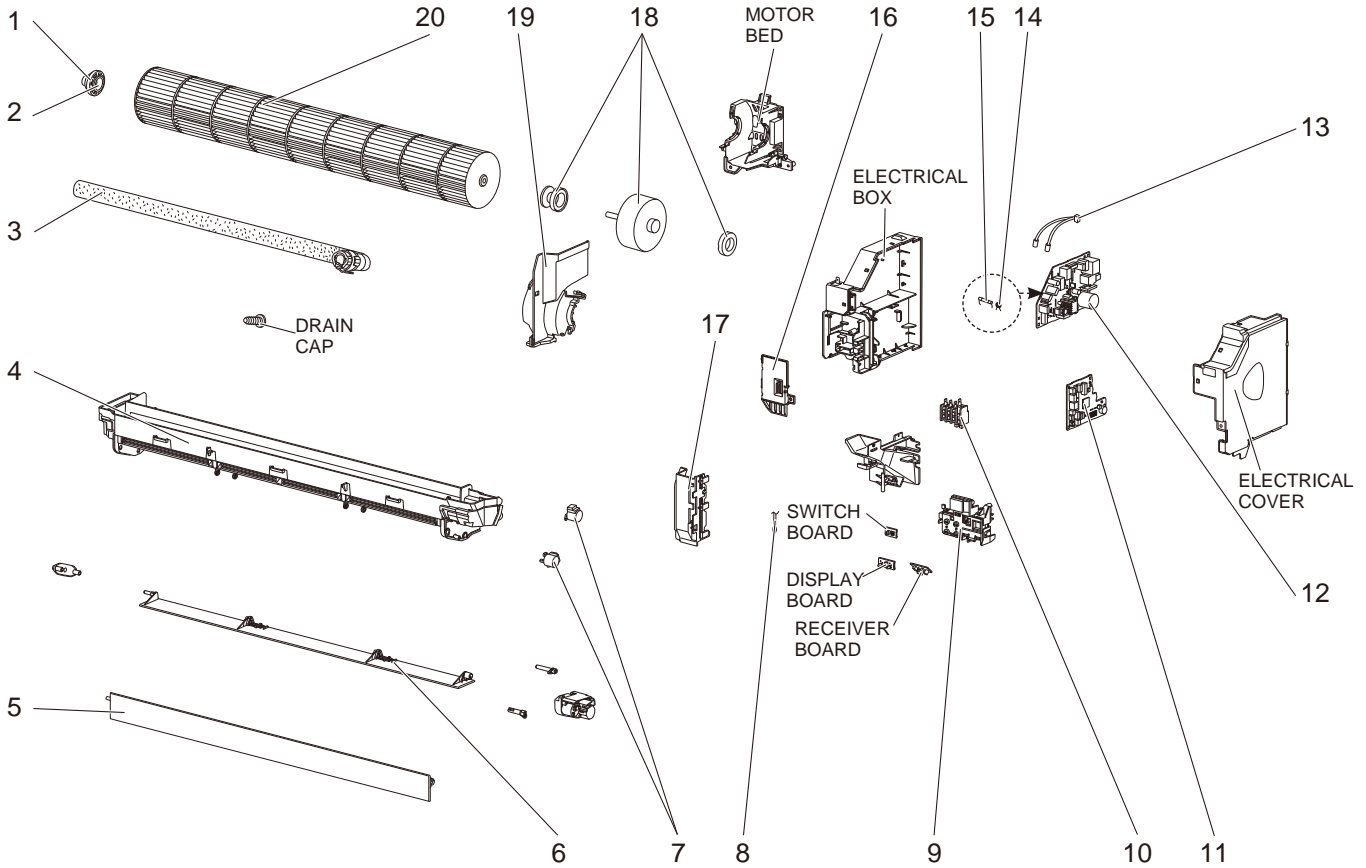

1-8. INDOOR UNIT HEAT EXCHANGER

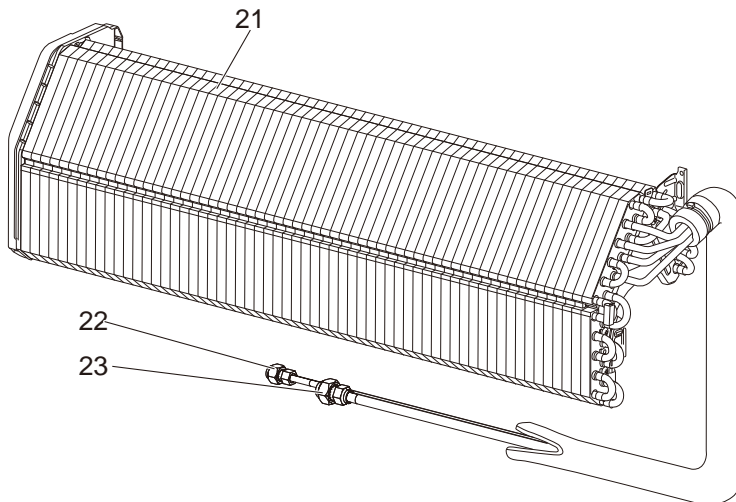

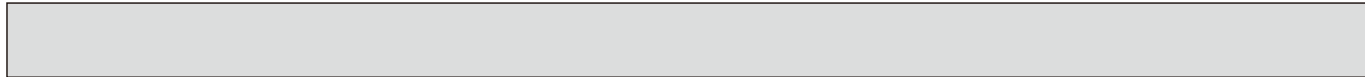

1-7. INDOOR UNIT ELECTRICAL PARTS AND FUNCTIONAL PARTS

No.	Part No.	Part name	Symbol in Wiring Diagram	Q'ty/unit																		Remarks
				MSZ-EF																		
				18			22			25			35			42			50			
VE2W	VE2B	VE2S	VE2W	VE2B	VE2S	VE2W	VE2B	VE2S	VE2W	VE2B	VE2S	VE2W	VE2B	VE2S	VE2W	VE2B	VE2S					
-E1	-E1	-E1	-E1	-E1	-E1	-E1	-E1	-E1	-E1	-E1	-E1	-E1	-E1	-E1	-E1	-E1	-E1					
1	E12 751 509	BEARING MOUNT		1	1	1	1	1	1	1	1	1	1	1	1	1	1	1				
2	E12 001 504	SLEEVE BEARING		1	1	1	1	1	1	1	1	1	1	1	1	1	1	1				
3	E12 897 702	DRAIN HOSE		1	1	1	1	1	1	1	1	1	1	1	1	1	1	1				
4	E12 F95 235	NOZZLE ASSEMBLY		1			1			1			1			1						
	E12 G21 235	NOZZLE ASSEMBLY			1			1			1			1			1					
	E12 G26 235	NOZZLE ASSEMBLY				1			1			1			1			1				
5	E12 F95 040	VANE UPPER		1			1			1			1			1						
	E12 G21 040	VANE UPPER			1			1			1			1			1					
	E12 G26 040	VANE UPPER				1			1			1			1			1				
6	E12 F95 041	VANE LOWER		1			1			1			1			1						
	E12 G21 041	VANE LOWER			1			1			1			1			1					
	E12 G26 041	VANE LOWER				1			1			1			1			1				
7	E12 A89 303	VANE MOTOR	MV	2	2	2	2	2	2	2	2	2	2	2	2	2	2	2				
8	E12 F95 308	ROOM TEMPERATURE THERMISTOR	RT11	1	1	1	1	1	1	1	1	1	1	1	1	1	1	1				
9	E12 F95 095	DISPLAY P.C. BOARD HOLDER		1	1	1	1	1	1	1	1	1	1	1	1	1	1	1				
10	E12 F95 375	TERMINAL BLOCK	TB	1	1	1	1	1	1	1	1	1	1	1	1	1	1	1				
11	E12 K14 452	ELECTRONIC CONTROL P.C. BOARD		1	1	1	1	1	1													
	E12 K15 452	ELECTRONIC CONTROL P.C. BOARD							1	1	1											
	E12 K16 452	ELECTRONIC CONTROL P.C. BOARD									1	1	1									
	E12 K17 452	ELECTRONIC CONTROL P.C. BOARD											1	1	1							
	E12 K18 452	ELECTRONIC CONTROL P.C. BOARD														1	1	1				
12	E12 F98 440	POWER P.C. BOARD		1	1	1	1	1	1	1	1	1	1	1	1	1	1	1				
13	E12 F95 307	INDOOR COIL THERMISTOR	RT12,RT13	1	1	1	1	1	1	1	1	1	1	1	1	1	1	1				
14	E12 B75 385	VARIATOR	NR11	1	1	1	1	1	1	1	1	1	1	1	1	1	1	1				
15	E12 A49 382	FUSE	F11	1	1	1	1	1	1	1	1	1	1	1	1	1	1	1				
16	E12 F95 784	V.A. CLAMP		1	1	1	1	1	1	1	1	1	1	1	1	1	1	1				
17	E12 F95 541	WATER CUT		1	1	1	1	1	1	1	1	1	1	1	1	1	1	1				
18	E12 F95 300	INDOOR FAN MOTOR	MF	1	1	1	1	1	1	1	1	1	1	1	1	1	1	1				
19	E12 F95 333	MOTOR BAND		1	1	1	1	1	1	1	1	1	1	1	1	1	1	1				
20	E12 F95 302	LINE FLOW FAN		1	1	1	1	1	1	1	1	1	1	1	1	1	1	1				

1-8. INDOOR UNIT HEAT EXCHANGER

No.	Part No.	Part name	Symbol in Wiring Diagram	Q'ty/unit																		Remarks
				MSZ-EF																		
				18			22			25			35			42			50			
VE2W	VE2B	VE2S	VE2W	VE2B	VE2S	VE2W	VE2B	VE2S	VE2W	VE2B	VE2S	VE2W	VE2B	VE2S	VE2W	VE2B	VE2S					
-E1	-E1	-E1	-E1	-E1	-E1	-E1	-E1	-E1	-E1	-E1	-E1	-E1	-E1	-E1	-E1	-E1	-E1					
21	E12 F95 620	INDOOR HEAT EXCHANGER		1	1	1	1	1	1	1	1	1	1	1	1	1						
	E12 F99 620	INDOOR HEAT EXCHANGER															1	1				
22	E12 151 667	UNION (LIQUID)		1	1	1	1	1	1	1	1	1	1	1	1	1	1	1				
23	E12 815 666	UNION (GAS)		1	1	1	1	1	1	1	1	1	1	1	1	1						
	E12 155 666	UNION (GAS)															1	1				

MSZ-EF18VE2W -ER1 MSZ-EF22VE2W -ER1 MSZ-EF25VE2W -ER1
MSZ-EF18VE2B -ER1 MSZ-EF22VE2B -ER1 MSZ-EF25VE2B -ER1
MSZ-EF18VE2S -ER1 MSZ-EF22VE2S -ER1 MSZ-EF25VE2S -ER1
MSZ-EF35VE2W -ER1 MSZ-EF42VE2W -ER1 MSZ-EF50VE2W -ER1
MSZ-EF35VE2B -ER1 MSZ-EF42VE2B -ER1 MSZ-EF50VE2B -ER1
MSZ-EF35VE2S -ER1 MSZ-EF42VE2S -ER1 MSZ-EF50VE2S -ER1

1-9. INDOOR UNIT STRUCTURAL PARTS

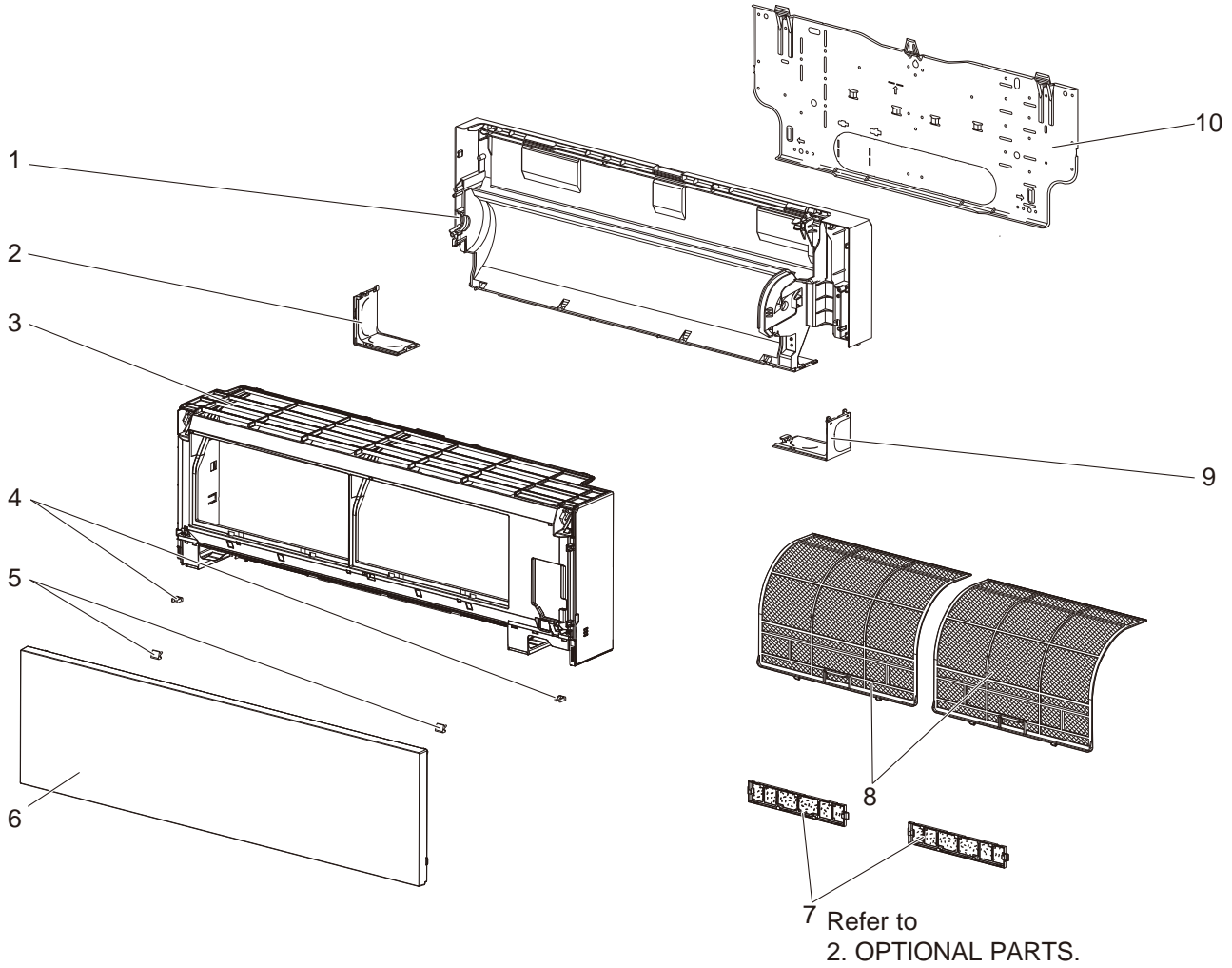

1-6. ACCESSORY AND REMOTE CONTROLLER

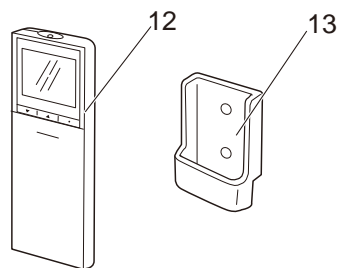

1-9. INDOOR UNIT STRUCTURAL PARTS

Part numbers that is circled is not shown in the illustration.

No.	Part No.	Part name	Symbol in Wiring Diagram	Q'ty/unit																		Remarks
				MSZ-EF																		
				18			22			25			35			42			50			
				VE2W -ER1	VE2B -ER1	VE2S -ER1	VE2W -ER1	VE2B -ER1	VE2S -ER1	VE2W -ER1	VE2B -ER1	VE2S -ER1	VE2W -ER1	VE2B -ER1	VE2S -ER1	VE2W -ER1	VE2B -ER1	VE2S -ER1	VE2W -ER1	VE2B -ER1	VE2S -ER1	
1	E12 F95 234	BOX ASSEMBLY		1		1			1			1			1			1				
	E12 G21 234	BOX ASSEMBLY			1		1			1			1			1		1				
	E12 G26 234	BOX ASSEMBLY				1		1			1			1			1					
2	E12 F95 976	CORNER BOX LEFT		1		1			1			1			1			1				
	E12 G21 976	CORNER BOX LEFT			1		1			1			1			1		1				
	E12 G26 976	CORNER BOX LEFT				1		1			1			1			1					
3	E12 M42 000	PANEL ASSEMBLY		1		1			1			1			1			1	Includes No. 4, 5, and 6			
	E12 M38 000	PANEL ASSEMBLY			1		1			1			1			1		1	Includes No. 4, 5, and 6			
	E12 M40 000	PANEL ASSEMBLY				1		1			1			1			1	Includes No. 4, 5, and 6				
4	E12 F95 142	CATCH		2	2	2	2	2	2	2	2	2	2	2	2	2	2	2	2	2 PCS/SET		
5	E12 F95 067	SCREW CAP		2			2			2			2			2		2	2 PCS/SET			
	E12 G21 067	SCREW CAP			2			2			2			2			2	2 PCS/SET				
	E12 G26 067	SCREW CAP				2			2			2			2		2	2 PCS/SET				
6	E12 M42 010	FRONT PANEL		1		1			1			1			1			1				
	E12 M38 010	FRONT PANEL			1		1			1			1			1		1				
	E12 M40 010	FRONT PANEL				1		1			1			1			1					
7	—	AIR CLEANING FILTER		2	2	2	2	2	2	2	2	2	2	2	2	2	2	2	2	1 PC/SET		
8	E12 F95 100	NANO PLATINUM FILTER		2	2	2	2	2	2	2	2	2	2	2	2	2	2	2	2	1 PC/SET		
9	E12 F95 975	CORNER BOX RIGHT		1		1			1			1			1			1				
	E12 G21 975	CORNER BOX RIGHT			1		1			1			1			1		1				
	E12 G26 975	CORNER BOX RIGHT				1		1			1			1			1					
10	E12 F95 970	INSTALLATION PLATE		1	1	1	1	1	1	1	1	1	1	1	1	1	1	1	1			
⑪	—	SOFT DRY CLOTH			1		1			1			1			1		1	MAC- 1001CL-E			

1-10. ACCESSORY AND REMOTE CONTROLLER

No.	Part No.	Part name	Symbol in Wiring Diagram	Q'ty/unit																		Remarks
				MSZ-EF																		
				18			22			25			35			42			50			
				VE2W -ER1	VE2B -ER1	VE2S -ER1	VE2W -ER1	VE2B -ER1	VE2S -ER1	VE2W -ER1	VE2B -ER1	VE2S -ER1	VE2W -ER1	VE2B -ER1	VE2S -ER1	VE2W -ER1	VE2B -ER1	VE2S -ER1	VE2W -ER1	VE2B -ER1	VE2S -ER1	
12	E12 M42 426	REMOTE CONTROLLER		1	1	1	1	1	1	1	1	1	1	1	1	1	1	1	1	SG14D		
13	E12 F28 083	REMOTE CONTROLLER HOLDER		1	1	1	1	1	1	1	1	1	1	1	1	1	1	1	1			

MSZ-EF18VE2W -[ER1] MSZ-EF22VE2W -[ER1] MSZ-EF25VE2W -[ER1]
MSZ-EF18VE2B -[ER1] MSZ-EF22VE2B -[ER1] MSZ-EF25VE2B -[ER1]
MSZ-EF18VE2S -[ER1] MSZ-EF22VE2S -[ER1] MSZ-EF25VE2S -[ER1]
MSZ-EF35VE2W -[ER1] MSZ-EF42VE2W -[ER1] MSZ-EF50VE2W -[ER1]
MSZ-EF35VE2B -[ER1] MSZ-EF42VE2B -[ER1] MSZ-EF50VE2B -[ER1]
MSZ-EF35VE2S -[ER1] MSZ-EF42VE2S -[ER1] MSZ-EF50VE2S -[ER1]

1-11. INDOOR UNIT ELECTRICAL PARTS AND FUNCTIONAL PARTS

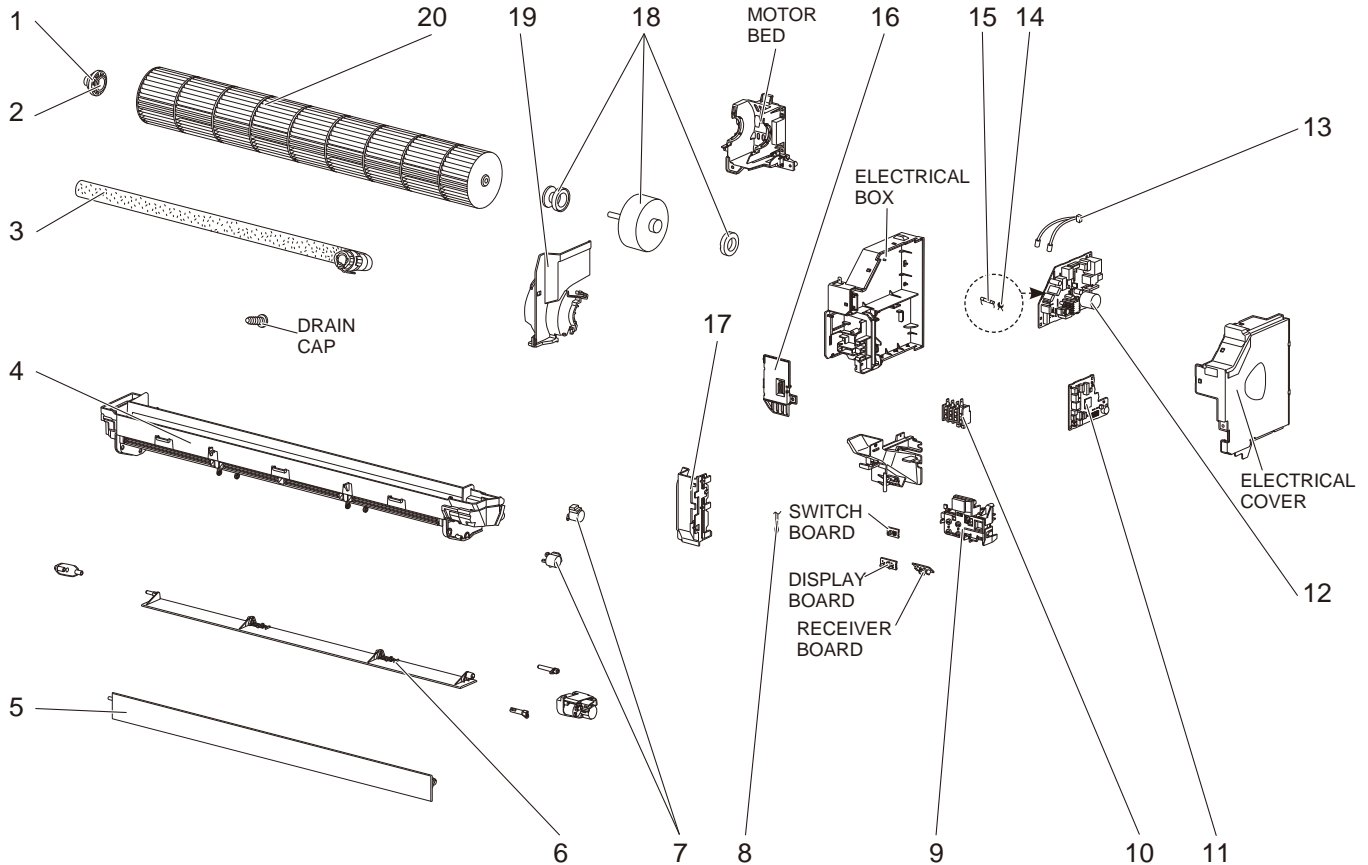

1-12. INDOOR UNIT HEAT EXCHANGER

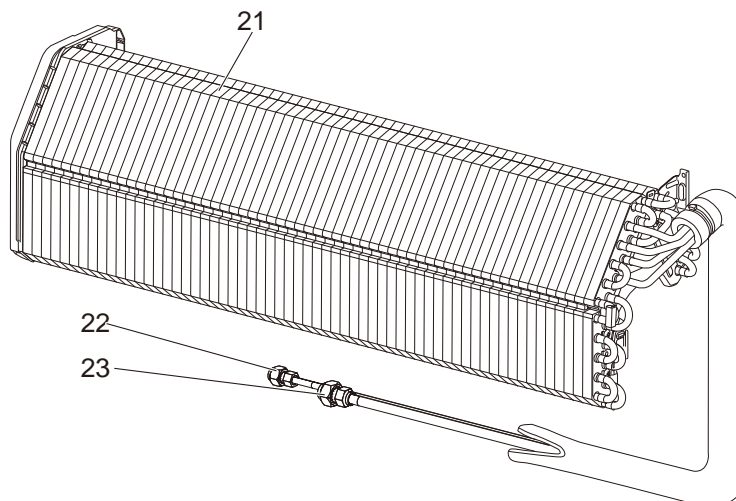

1-11. INDOOR UNIT ELECTRICAL PARTS AND FUNCTIONAL PARTS

No.	Part No.	Part name	Symbol in Wiring Diagram	Q'ty/unit																		Remarks
				MSZ-EF																		
				18			22			25			35			42			50			
				VE2W	VE2B	VE2S	VE2W	VE2B	VE2S	VE2W	VE2B	VE2S	VE2W	VE2B	VE2S	VE2W	VE2B	VE2S	VE2W	VE2B	VE2S	
1	E12 751 509	BEARING MOUNT		1	1	1	1	1	1	1	1	1	1	1	1	1	1	1	1			
2	E12 001 504	SLEEVE BEARING		1	1	1	1	1	1	1	1	1	1	1	1	1	1	1	1			
3	E12 897 702	DRAIN HOSE		1	1	1	1	1	1	1	1	1	1	1	1	1	1	1	1			
4	E12 F95 235	NOZZLE ASSEMBLY		1			1			1			1			1			1			
	E12 G21 235	NOZZLE ASSEMBLY			1			1			1			1			1			1		
	E12 G26 235	NOZZLE ASSEMBLY				1			1			1			1			1			1	
5	E12 F95 040	VANE UPPER		1			1			1			1			1			1			
	E12 G21 040	VANE UPPER			1			1			1			1			1			1		
	E12 G26 040	VANE UPPER				1			1			1			1			1			1	
6	E12 F95 041	VANE LOWER		1			1			1			1			1			1			
	E12 G21 041	VANE LOWER			1			1			1			1			1			1		
	E12 G26 041	VANE LOWER				1			1			1			1			1			1	
7	E12 A89 303	VANE MOTOR	MV	2	2	2	2	2	2	2	2	2	2	2	2	2	2	2	2	2	2	UP & DOWN, 1 PC/SET
8	E12 F95 308	ROOM TEMPERATURE THERMISTOR	RT11	1	1	1	1	1	1	1	1	1	1	1	1	1	1	1	1	1	1	
9	E12 F95 095	DISPLAY P.C. BOARD HOLDER		1	1	1	1	1	1	1	1	1	1	1	1	1	1	1	1	1	1	
10	E12 F95 375	TERMINAL BLOCK	TB	1	1	1	1	1	1	1	1	1	1	1	1	1	1	1	1	1	1	
11	E12 K14 452	ELECTRONIC CONTROL P.C. BOARD		1	1	1	1	1	1													Includes RECEIVER BOARD, DISPLAY BOARD and SWITCH BOARD.
	E12 K15 452	ELECTRONIC CONTROL P.C. BOARD								1	1	1										
	E12 K16 452	ELECTRONIC CONTROL P.C. BOARD											1	1	1							
	E12 K17 452	ELECTRONIC CONTROL P.C. BOARD														1	1	1				
	E12 K18 452	ELECTRONIC CONTROL P.C. BOARD																	1	1	1	
12	E12 F98 440	POWER P.C. BOARD		1	1	1	1	1	1	1	1	1	1	1	1	1	1	1	1	1	1	
13	E12 F95 307	INDOOR COIL THERMISTOR	RT12,RT13	1	1	1	1	1	1	1	1	1	1	1	1	1	1	1	1	1	1	
14	E12 B75 385	VARISTOR	NR11	1	1	1	1	1	1	1	1	1	1	1	1	1	1	1	1	1	1	
15	E12 A49 382	FUSE	F11	1	1	1	1	1	1	1	1	1	1	1	1	1	1	1	1	1	1	T3.15AL250V
16	E12 F95 784	V.A. CLAMP		1	1	1	1	1	1	1	1	1	1	1	1	1	1	1	1	1	1	
17	E12 F95 541	WATER CUT		1	1	1	1	1	1	1	1	1	1	1	1	1	1	1	1	1	1	
18	E12 F95 300	INDOOR FAN MOTOR	MF	1	1	1	1	1	1	1	1	1	1	1	1	1	1	1	1	1	1	RC0J40-□□ Includes FAN MOTOR RUBBER MOUNT (2 PCS/SET)
19	E12 F95 333	MOTOR BAND		1	1	1	1	1	1	1	1	1	1	1	1	1	1	1	1	1	1	
20	E12 F95 302	LINE FLOW FAN		1	1	1	1	1	1	1	1	1	1	1	1	1	1	1	1	1	1	

1-12. INDOOR UNIT HEAT EXCHANGER

No.	Part No.	Part name	Symbol in Wiring Diagram	Q'ty/unit																		Remarks
				MSZ-EF																		
				18			22			25			35			42			50			
				VE2W	VE2B	VE2S	VE2W	VE2B	VE2S	VE2W	VE2B	VE2S	VE2W	VE2B	VE2S	VE2W	VE2B	VE2S	VE2W	VE2B	VE2S	
21	E12 F95 620	INDOOR HEAT EXCHANGER		1	1	1	1	1	1	1	1	1	1	1	1	1	1	1	1	1	1	
	E12 F99 620	INDOOR HEAT EXCHANGER																	1	1	1	
22	E12 151 667	UNION (LIQUID)		1	1	1	1	1	1	1	1	1	1	1	1	1	1	1	1	1	1	ø6.35
23	E12 815 666	UNION (GAS)		1	1	1	1	1	1	1	1	1	1	1	1	1	1	1	1	1	1	ø9.52
	E12 155 666	UNION (GAS)																	1	1	1	ø12.7

MSZ-EF18VE3W -E1 MSZ-EF22VE3W -E1 MSZ-EF25VE3S -E1 MSZ-EF42VE3B -E1
 MSZ-EF18VE3B -E1 MSZ-EF22VE3B -E1 MSZ-EF35VE3S -E1 MSZ-EF42VE3S -E1
 MSZ-EF18VE3S -E1 MSZ-EF22VE3S -E1 MSZ-EF42VE3W -E1 MSZ-EF50VE3S -E1

1-12. INDOOR UNIT STRUCTURAL PARTS

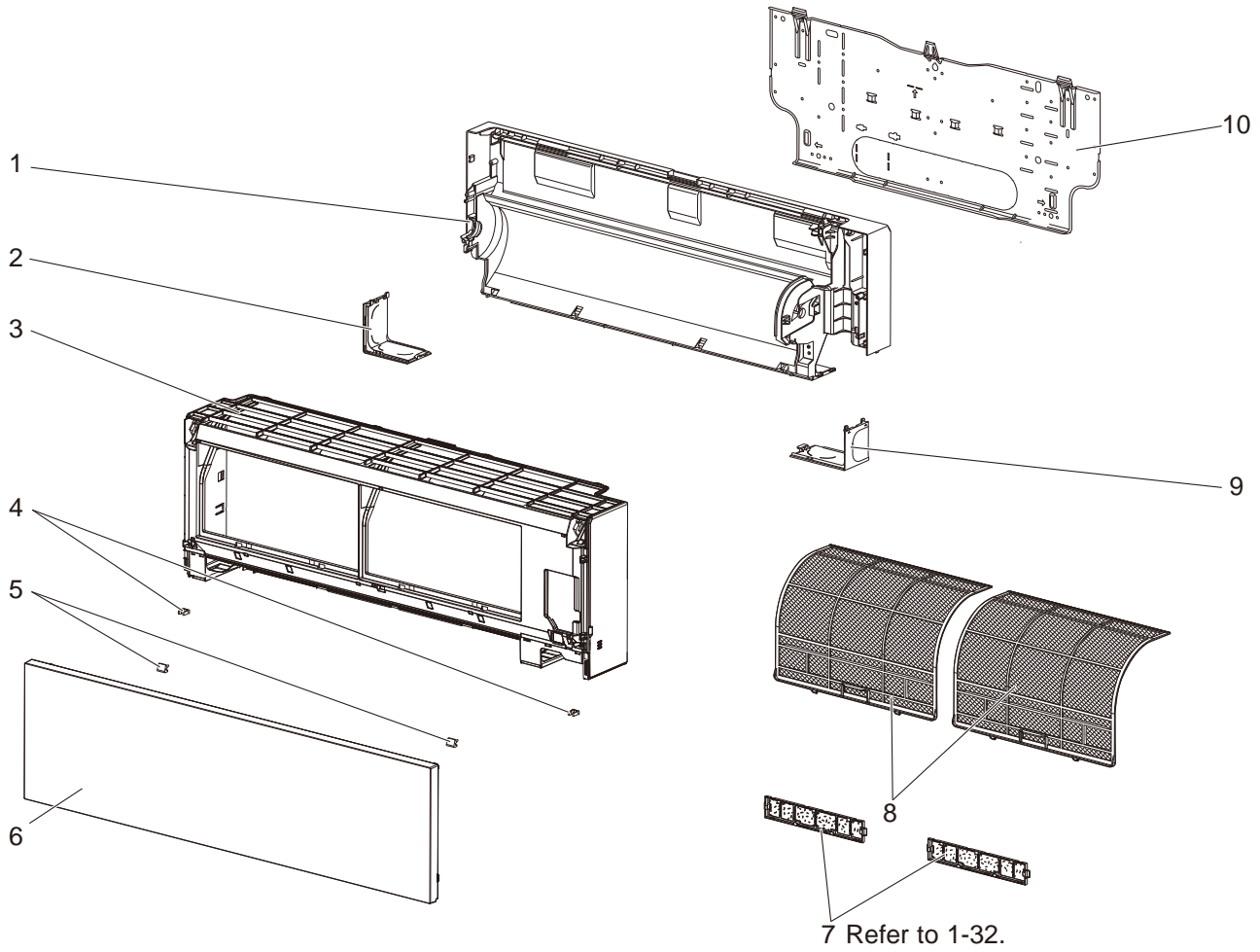

1-13. ACCESSORY AND REMOTE CONTROLLER

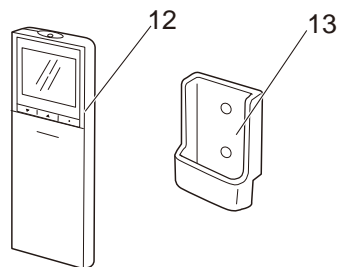

1-12. INDOOR UNIT STRUCTURAL PARTS

Part numbers that is circled is not shown in the illustration.

No.	Part No.	Part name	Symbol in Wiring Diagram	Q'ty/unit										Remarks			
				MSZ-EF													
				18			22			25	35	42			50		
				VE3W -E1	VE3B -E1	VE3S -E1	VE3W -E1	VE3B -E1	VE3S -E1	VE3S -E1	VE3S -E1	VE3W -E1	VE3B -E1		VE3S -E1		
1	E12 F95 234	BOX ASSEMBLY		1			1						1				
	E12 G21 234	BOX ASSEMBLY			1		1						1				
	E12 G26 234	BOX ASSEMBLY				1		1	1	1				1	1		
2	E12 F95 976	CORNER BOX LEFT		1			1						1				
	E12 G21 976	CORNER BOX LEFT			1			1					1				
	E12 G26 976	CORNER BOX LEFT				1			1	1	1			1	1		
3	E12 W14 000	PANEL ASSEMBLY		1			1						1			Includes No. 4, 5, and 6	
	E12 W26 000	PANEL ASSEMBLY			1			1					1			Includes No. 4, 5, and 6	
	E12 W20 000	PANEL ASSEMBLY				1			1	1	1			1	1	Includes No. 4, 5, and 6	
4	E12 F95 142	CATCH		2	2	2	2	2	2	2	2	2	2	2	2	2	2 PCS/SET
5	E12 F95 067	SCREW CAP		2			2						2				2 PCS/SET
	E12 G21 067	SCREW CAP			2			2					2				2 PCS/SET
	E12 G26 067	SCREW CAP				2			2	2	2			2	2		2 PCS/SET
6	E12 T21 010	FRONT PANEL		1			1						1				
	E12 T25 010	FRONT PANEL			1			1					1				
	E12 T29 010	FRONT PANEL				1			1	1	1			1	1		
7	—	AIR CLEANING FILTER (SILVER-IONIZED AIR PURIFIER FILTER)		2	2	2	2	2	2	2	2	2	2	2	2	2	1 PC/SET
8	E12 W14 100	AIR FILTER (AIR PURIFYING FILTER)		2	2	2	2	2	2	2	2	2	2	2	2	2	1 PC/SET
9	E12 F95 975	CORNER BOX RIGHT		1			1						1				
	E12 G21 975	CORNER BOX RIGHT			1			1					1				
	E12 G26 975	CORNER BOX RIGHT				1			1	1	1			1	1		
10	E12 F95 970	INSTALLATION PLATE		1	1	1	1	1	1	1	1	1	1	1	1	1	
⑪	—	SOFT DRY CLOTH			1			1						1			MAC-1001CL-E

1-13. ACCESSORY AND REMOTE CONTROLLER

No.	Part No.	Part name	Symbol in Wiring Diagram	Q'ty/unit										Remarks			
				MSZ-EF													
				18			22			25	35	42			50		
				VE3W -E1	VE3B -E1	VE3S -E1	VE3W -E1	VE3B -E1	VE3S -E1	VE3S -E1	VE3S -E1	VE3W -E1	VE3B -E1		VE3S -E1		
12	E12 R80 426	REMOTE CONTROLLER		1	1	1	1	1	1	1	1	1	1	1	1	1	SG15D
13	E12 F28 083	REMOTE CONTROLLER HOLDER		1	1	1	1	1	1	1	1	1	1	1	1	1	

MSZ-EF18VE3W -[E1] MSZ-EF22VE3W -[E1] MSZ-EF25VE3S -[E1] MSZ-EF42VE3B -[E1]
 MSZ-EF18VE3B -[E1] MSZ-EF22VE3B -[E1] MSZ-EF35VE3S -[E1] MSZ-EF42VE3S -[E1]
 MSZ-EF18VE3S -[E1] MSZ-EF22VE3S -[E1] MSZ-EF42VE3W -[E1] MSZ-EF50VE3S -[E1]

1-14. INDOOR UNIT ELECTRICAL PARTS AND FUNCTIONAL PARTS

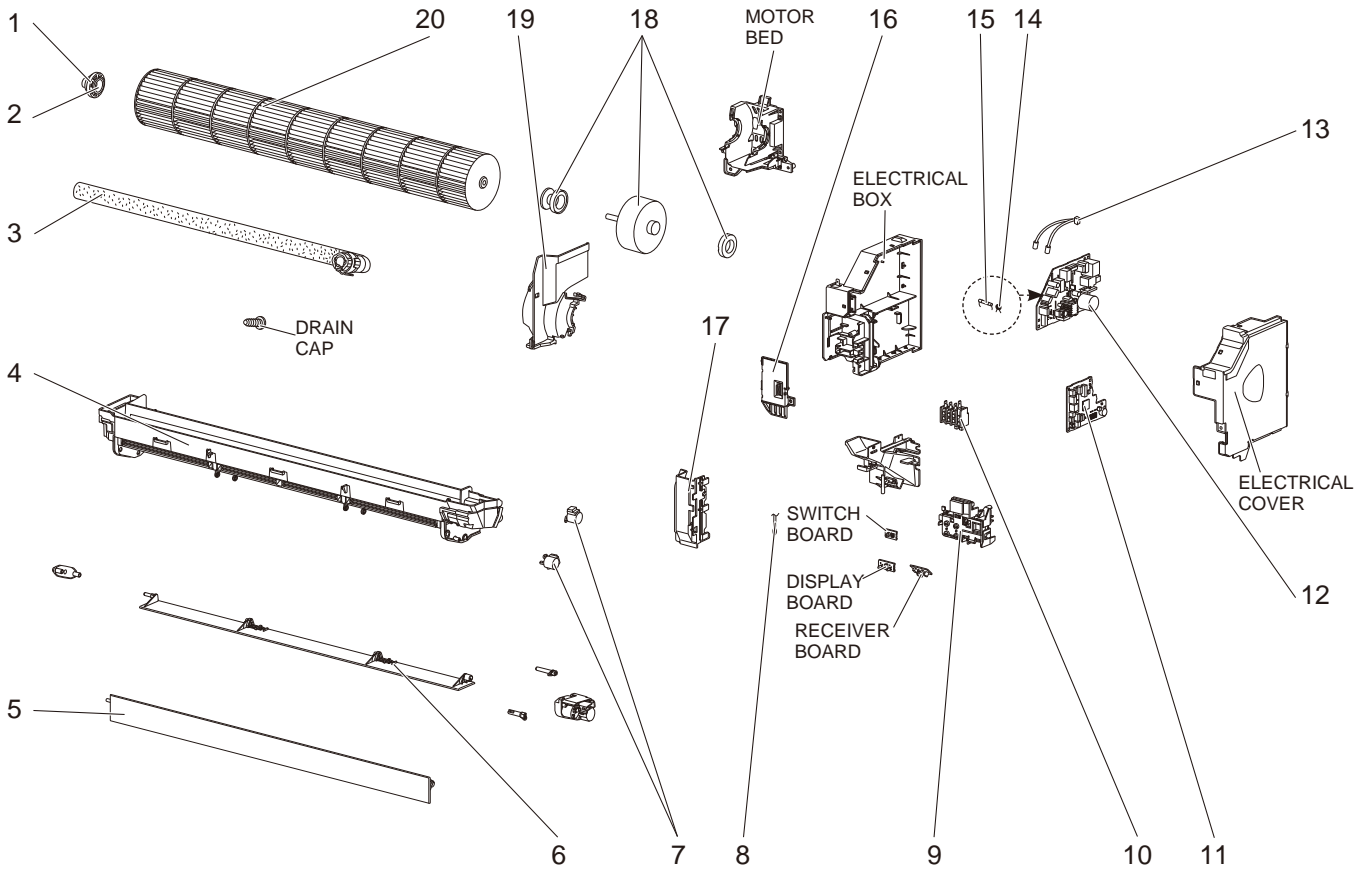

1-15. INDOOR UNIT HEAT EXCHANGER

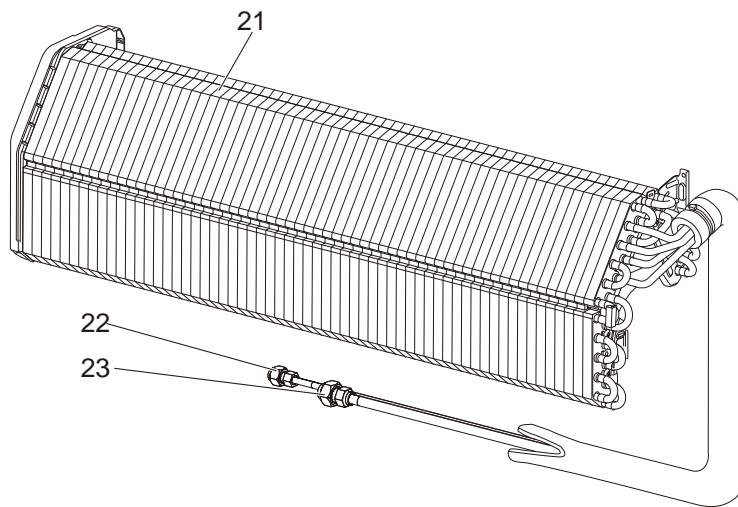

1-14. INDOOR UNIT ELECTRICAL PARTS AND FUNCTIONAL PARTS

No.	Part No.	Part name	Symbol in Wiring Diagram	Q'ty/unit										Remarks	
				MSZ-EF											
				18			22			25	35	42			50
VE3W -E1	VE3B -E1	VE3S -E1	VE3W -E1	VE3B -E1	VE3S -E1	VE3S -E1	VE3S -E1	VE3W -E1	VE3B -E1	VE3S -E1	VE3S -E1				
1	E12 751 509	BEARING MOUNT		1	1	1	1	1	1	1	1	1	1	1	
2	E12 001 504	SLEEVE BEARING		1	1	1	1	1	1	1	1	1	1	1	
3	E12 897 702	DRAIN HOSE		1	1	1	1	1	1	1	1	1	1	1	
4	E12 F95 235	NOZZLE ASSEMBLY		1			1					1			
	E12 G21 235	NOZZLE ASSEMBLY			1			1					1		
	E12 G26 235	NOZZLE ASSEMBLY				1			1	1	1			1	1
5	E12 F95 040	VANE UPPER		1			1					1			
	E12 G21 040	VANE UPPER			1			1					1		
	E12 G26 040	VANE UPPER				1			1	1	1			1	1
6	E12 F95 041	VANE LOWER		1			1					1			
	E12 G21 041	VANE LOWER			1			1					1		
	E12 G26 041	VANE LOWER				1			1	1	1			1	1
7	E12 A89 303	VANE MOTOR	MV	2	2	2	2	2	2	2	2	2	2	2	UP & DOWN, 1 PC/SET
8	E12 F95 308	ROOM TEMPERATURE THERMISTOR	RT11	1	1	1	1	1	1	1	1	1	1	1	1
9	E12 F95 095	DISPLAY P.C. BOARD HOLDER		1	1	1	1	1	1	1	1	1	1	1	1
10	E12 T21 375	TERMINAL BLOCK	TB	1	1	1	1	1	1	1	1	1	1	1	1
11	E12 K14 452	ELECTRONIC CONTROL P.C. BOARD		1	1	1	1	1	1						
	E12 K15 452	ELECTRONIC CONTROL P.C. BOARD								1					
	E12 K16 452	ELECTRONIC CONTROL P.C. BOARD									1				
	E12 K17 452	ELECTRONIC CONTROL P.C. BOARD										1	1	1	
	E12 K18 452	ELECTRONIC CONTROL P.C. BOARD													1
12	E12 F98 440	POWER P.C. BOARD		1	1	1	1	1	1	1	1	1	1	1	1
13	E12 F95 307	INDOOR COIL THERMISTOR	RT12,RT13	1	1	1	1	1	1	1	1	1	1	1	1
14	E12 B75 385	VARISTOR	NR11	1	1	1	1	1	1	1	1	1	1	1	1
15	E12 A49 382	FUSE	F11	1	1	1	1	1	1	1	1	1	1	1	T3.15AL250V
16	E12 F95 784	V.A. CLAMP		1	1	1	1	1	1	1	1	1	1	1	1
17	E12 F95 541	WATER CUT		1	1	1	1	1	1	1	1	1	1	1	1
18	E12 J44 300	INDOOR FAN MOTOR	MF	1	1	1	1	1	1	1	1	1	1	1	RC0J40-□□ Includes FAN MOTOR RUBBER MOUNT (2 PCS/SET)
19	E12 F95 333	MOTOR BAND		1	1	1	1	1	1	1	1	1	1	1	1
20	E12 F95 302	LINE FLOW FAN		1	1	1	1	1	1	1	1	1	1	1	1

1-15. INDOOR UNIT HEAT EXCHANGER

No.	Part No.	Part name	Symbol in Wiring Diagram	Q'ty/unit										Remarks	
				MSZ-EF											
				18			22			25	35	42			50
VE3W -E1	VE3B -E1	VE3S -E1	VE3W -E1	VE3B -E1	VE3S -E1	VE3S -E1	VE3S -E1	VE3W -E1	VE3B -E1	VE3S -E1	VE3S -E1				
21	E12 F95 620	INDOOR HEAT EXCHANGER		1	1	1	1	1	1	1	1	1	1		
	E12 F99 620	INDOOR HEAT EXCHANGER													1
22	E12 151 667	UNION (LIQUID)		1	1	1	1	1	1	1	1	1	1	1	ø6.35
23	E12 815 666	UNION (GAS)		1	1	1	1	1	1	1	1	1	1		ø9.52
	E12 155 666	UNION (GAS)												1	ø12.7

MSZ-EF25VE3W -E1

MSZ-EF25VE3B -E1

MSZ-EF35VE3W -E1

MSZ-EF35VE3B -E1

MSZ-EF50VE3W -E1

MSZ-EF50VE3B -E1

1-16. INDOOR UNIT STRUCTURAL PARTS

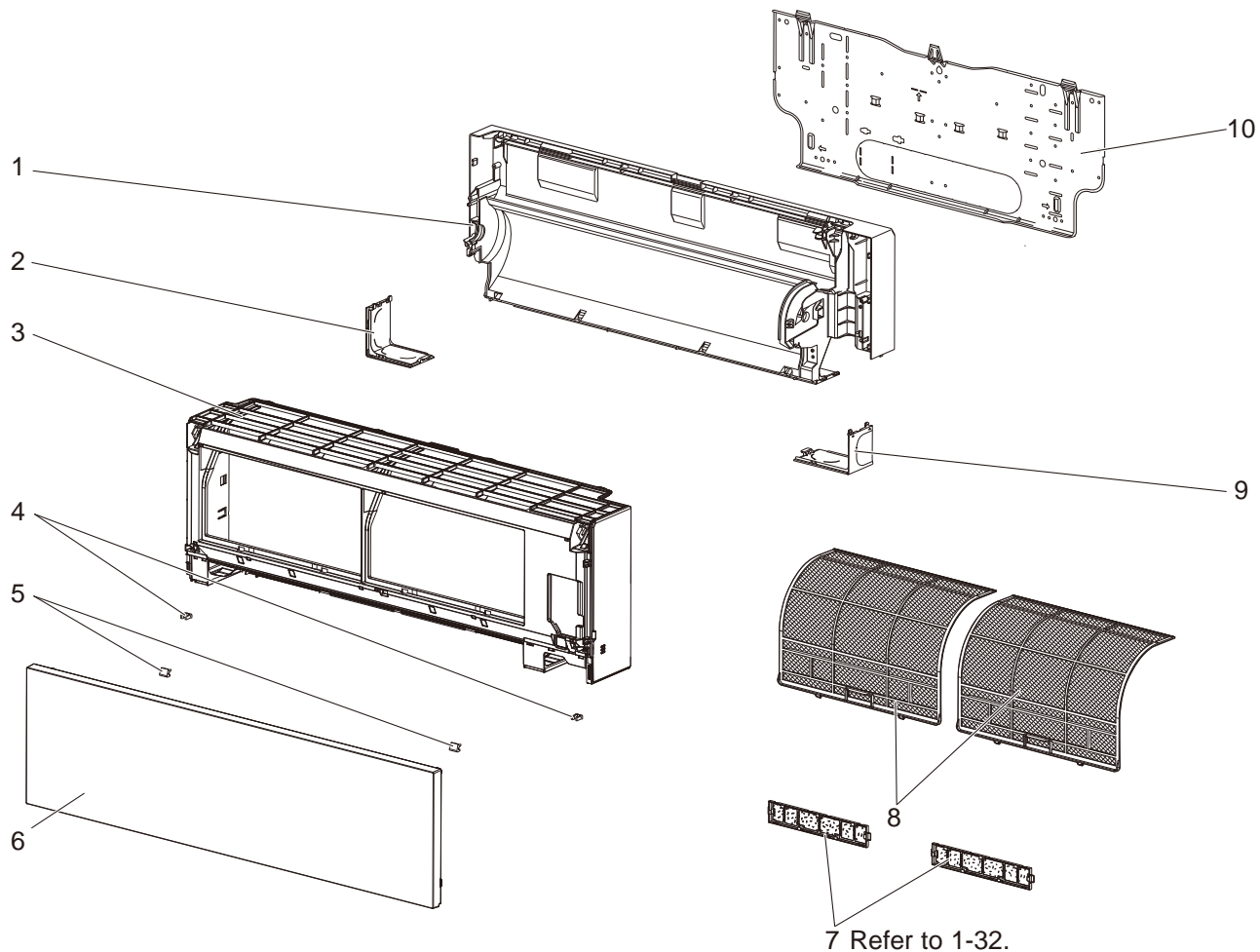

1-17. ACCESSORY AND REMOTE CONTROLLER

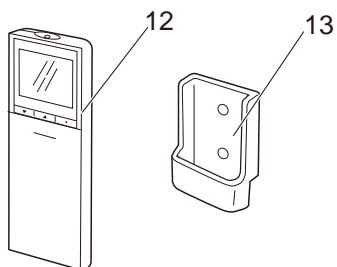

1-16. INDOOR UNIT STRUCTURAL PARTS

Part numbers that is circled is not shown in the illustration.

No.	Part No.	Part name	Symbol in Wiring Diagram	Q'ty/unit						Remarks
				MSZ-EF						
				25		35		50		
				VE3W -E1	VE3B -E1	VE3W -E1	VE3B -E1	VE3W -E1	VE3B -E1	
1	E22 F95 234	BOX ASSEMBLY		1		1		1		
	E22 G21 234	BOX ASSEMBLY			1		1		1	
2	E22 F95 976	CORNER BOX LEFT		1		1		1		
	E22 G21 976	CORNER BOX LEFT			1		1		1	
3	E22 W14 000	PANEL ASSEMBLY		1		1		1		Includes No. 4, 5, and 6
	E22 W26 000	PANEL ASSEMBLY			1		1		1	Includes No. 4, 5, and 6
4	E22 F95 142	CATCH		2	2	2	2	2	2	2 PCS/SET
5	E22 F95 067	SCREW CAP		2		2		2		2 PCS/SET
	E22 G21 067	SCREW CAP			2		2		2	2 PCS/SET
6	E22 T21 010	FRONT PANEL		1		1		1		
	E22 T25 010	FRONT PANEL			1		1		1	
7	—	AIR CLEANING FILTER (SILVER-IONIZED AIR PURIFIER FILTER)		2	2	2	2	2	2	1 PC/SET
8	E22 W14 100	AIR FILTER (AIR PURIFYING FILTER)		2	2	2	2	2	2	1 PC/SET
9	E22 F95 975	CORNER BOX RIGHT		1		1		1		
	E22 G21 975	CORNER BOX RIGHT			1		1		1	
10	E22 F95 970	INSTALLATION PLATE		1	1	1	1	1	1	
⑪	—	SOFT DRY CLOTH			1		1		1	MAC-1001CL-E

1-17. ACCESSORY AND REMOTE CONTROLLER

No.	Part No.	Part name	Symbol in Wiring Diagram	Q'ty/unit						Remarks
				MSZ-EF						
				25		35		50		
				VE3W -E1	VE3B -E1	VE3W -E1	VE3B -E1	VE3W -E1	VE3B -E1	
12	E22 R80 426	REMOTE CONTROLLER		1	1	1	1	1	1	SG15D
13	E22 F28 083	REMOTE CONTROLLER HOLDER		1	1	1	1	1	1	

MSZ-EF25VE3W -[E1]

MSZ-EF25VE3B -[E1]

MSZ-EF35VE3W -[E1]

MSZ-EF35VE3B -[E1]

MSZ-EF50VE3W -[E1]

MSZ-EF50VE3B -[E1]

1-18. INDOOR UNIT ELECTRICAL PARTS AND FUNCTIONAL PARTS

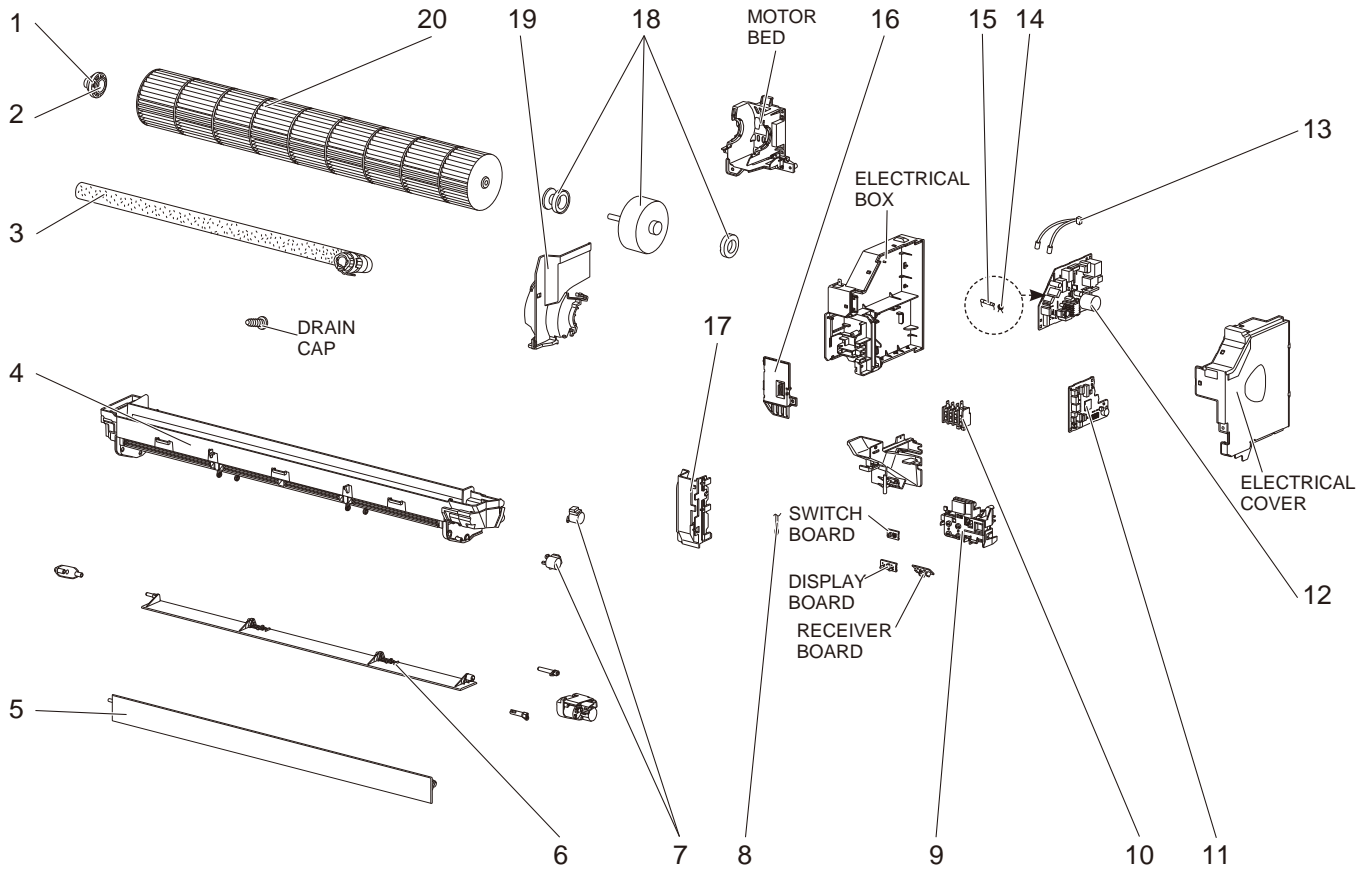

1-19. INDOOR UNIT HEAT EXCHANGER

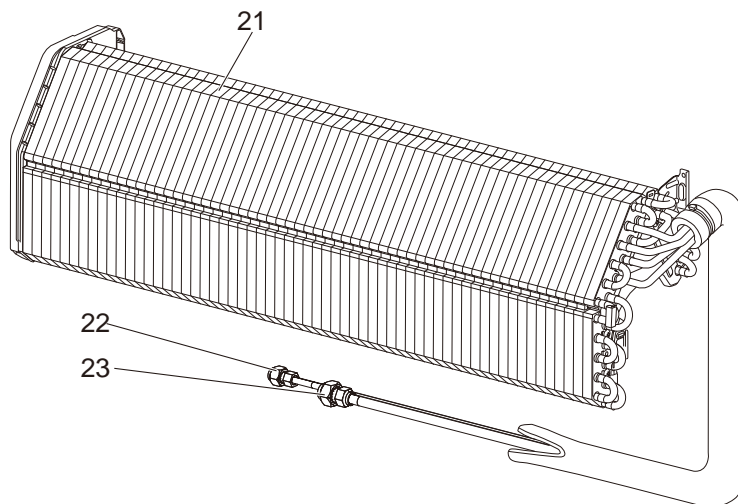

1-18. INDOOR UNIT ELECTRICAL PARTS AND FUNCTIONAL PARTS

No.	Part No.	Part name	Symbol in Wiring Diagram	Q'ty/unit						Remarks
				MSZ-EF						
				25		35		50		
				VE3W -E1	VE3B -E1	VE3W -E1	VE3B -E1	VE3W -E1	VE3B -E1	
1	E22 751 509	BEARING MOUNT		1	1	1	1	1	1	
2	E22 001 504	SLEEVE BEARING		1	1	1	1	1	1	
3	E22 P72 702	DRAIN HOSE		1	1	1	1	1	1	
4	E22 F95 235	NOZZLE ASSEMBLY		1		1		1		
	E22 G21 235	NOZZLE ASSEMBLY			1		1		1	
5	E22 F95 040	VANE UPPER		1		1		1		
	E22 G21 040	VANE UPPER			1		1		1	
6	E22 F95 041	VANE LOWER		1		1		1		
	E22 G21 041	VANE LOWER			1		1		1	
7	E22 A89 303	VANE MOTOR	MV	2	2	2	2	2	2	UP & DOWN, 1 PC/SET
8	E22 F95 308	ROOM TEMPERATURE THERMISTOR	RT11	1	1	1	1	1	1	
9	E22 F95 095	DISPLAY P.C. BOARD HOLDER		1	1	1	1	1	1	
10	E22 T21 375	TERMINAL BLOCK	TB	1	1	1	1	1	1	
11	E22 K15 452	ELECTRONIC CONTROL P.C. BOARD		1	1					Includes RECEIVER BOARD, DISPLAY BOARD and SWITCH BOARD.
	E22 K16 452	ELECTRONIC CONTROL P.C. BOARD				1	1			
	E22 K18 452	ELECTRONIC CONTROL P.C. BOARD						1	1	
12	E22 F98 440	POWER P.C. BOARD		1	1	1	1	1	1	
13	E22 F95 307	INDOOR COIL THERMISTOR	RT12, RT13	1	1	1	1	1	1	
14	E22 B75 385	VARISTOR	NR11	1	1	1	1	1	1	
15	E22 A49 382	FUSE	F11	1	1	1	1	1	1	T3.15AL250V
16	E22 F95 784	V.A. CLAMP		1	1	1	1	1	1	
17	E22 F95 541	WATER CUT		1	1	1	1	1	1	
18	E22 J44 300	INDOOR FAN MOTOR	MF	1	1	1	1	1	1	RC0J40-□□ Includes FAN MOTOR RUBBER MOUNT (2 PCS/SET)
19	E22 F95 333	MOTOR BAND		1	1	1	1	1	1	
20	E22 F95 302	LINE FLOW FAN		1	1	1	1	1	1	

1-19. INDOOR UNIT HEAT EXCHANGER

No.	Part No.	Part name	Symbol in Wiring Diagram	Q'ty/unit						Remarks
				MSZ-EF						
				25		35		50		
				VE3W -E1	VE3B -E1	VE3W -E1	VE3B -E1	VE3W -E1	VE3B -E1	
21	E22 F95 620	INDOOR HEAT EXCHANGER		1	1	1	1			
	E22 F99 620	INDOOR HEAT EXCHANGER						1	1	
22	E22 151 667	UNION (LIQUID)		1	1	1	1	1	1	ø6.35
23	E22 815 666	UNION (GAS)		1	1	1	1			ø9.52
	E22 155 666	UNION (GAS)						1	1	ø12.7

MSZ-EF18VE3W -E2 MSZ-EF22VE3W -E2 MSZ-EF25VE3W -E2
 MSZ-EF18VE3B -E2 MSZ-EF22VE3B -E2 MSZ-EF25VE3B -E2
 MSZ-EF18VE3S -E2 MSZ-EF22VE3S -E2 MSZ-EF25VE3S -E2
 MSZ-EF35VE3W -E2 MSZ-EF42VE3W -E2 MSZ-EF50VE3W -E2
 MSZ-EF35VE3B -E2 MSZ-EF42VE3B -E2 MSZ-EF50VE3B -E2
 MSZ-EF35VE3S -E2 MSZ-EF42VE3S -E2 MSZ-EF50VE3S -E2

1-20. INDOOR UNIT STRUCTURAL PARTS

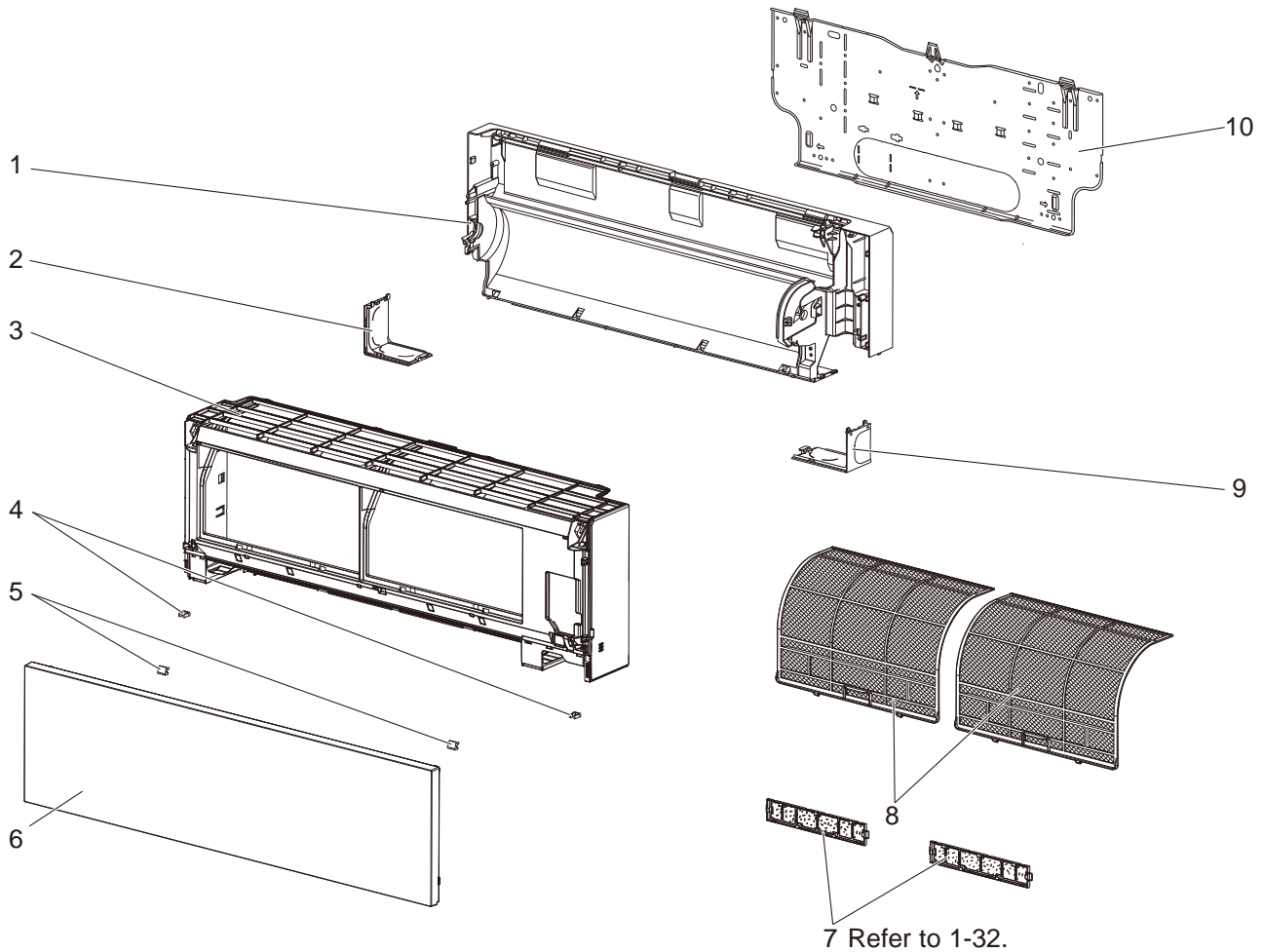

1-21. ACCESSORY AND REMOTE CONTROLLER

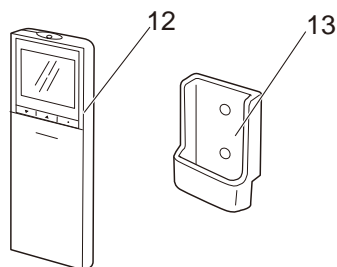

1-20 INDOOR UNIT STRUCTURAL PARTS

Part numbers that is circled is not shown in the illustration.

No.	Part No.	Part name	Symbol in Wiring Diagram	Q'ty/unit																		Remarks
				MSZ-EF																		
				18			22			25			35			42			50			
				VE3W -E2	VE3B -E2	VE3S -E2	VE3W -E2	VE3B -E2	VE3S -E2	VE3W -E2	VE3B -E2	VE3S -E2	VE3W -E2	VE3B -E2	VE3S -E2	VE3W -E2	VE3B -E2	VE3S -E2	VE3W -E2	VE3B -E2	VE3S -E2	
1	E22 F95 234	BOX ASSEMBLY		1			1			1			1			1			1			
	E22 G21 234	BOX ASSEMBLY			1			1			1			1			1			1		
	E22 G26 234	BOX ASSEMBLY				1			1			1			1			1			1	
2	E22 F95 976	CORNER BOX LEFT		1			1			1			1			1			1			
	E22 G21 976	CORNER BOX LEFT			1			1			1			1			1			1		
	E22 G26 976	CORNER BOX LEFT				1			1			1			1			1			1	
3	E22 W14 000	PANEL ASSEMBLY		1			1			1			1			1			1			Includes No. 4, 5, and 6
	E22 W26 000	PANEL ASSEMBLY			1			1			1			1			1			1		Includes No. 4, 5, and 6
	E22 W20 000	PANEL ASSEMBLY				1			1			1			1			1			1	Includes No. 4, 5, and 6
4	E22 F95 142	CATCH		2	2	2	2	2	2	2	2	2	2	2	2	2	2	2	2	2	2	2 PCS/SET
5	E22 F95 067	SCREW CAP		2			2			2			2			2			2			2 PCS/SET
	E22 G21 067	SCREW CAP			2			2			2			2			2			2		2 PCS/SET
	E22 G26 067	SCREW CAP				2			2			2			2			2			2	2 PCS/SET
6	E22 T21 010	FRONT PANEL		1			1			1			1			1			1			
	E22 T25 010	FRONT PANEL			1			1			1			1			1			1		
	E22 T29 010	FRONT PANEL				1			1			1			1			1			1	
7	—	AIR CLEANING FILTER (SILVER-IONIZED AIR PURIFIER FILTER)		2	2	2	2	2	2	2	2	2	2	2	2	2	2	2	2	2	2	1 PC/SET
8	E22 W14 100	AIR FILTER (AIR PURIFYING FILTER)		2	2	2	2	2	2	2	2	2	2	2	2	2	2	2	2	2	2	1 PC/SET
9	E22 F95 975	CORNER BOX RIGHT		1			1			1			1			1			1			
	E22 G21 975	CORNER BOX RIGHT			1			1			1			1			1			1		
	E22 G26 975	CORNER BOX RIGHT				1			1			1			1			1			1	
10	E22 F95 970	INSTALLATION PLATE		1	1	1	1	1	1	1	1	1	1	1	1	1	1	1	1	1	1	
⑪	—	SOFT DRY CLOTH				1			1			1			1			1			1	MAC- 1001CL-E

1-21. ACCESSORY AND REMOTE CONTROLLER

No.	Part No.	Part name	Symbol in Wiring Diagram	Q'ty/unit																		Remarks
				MSZ-EF																		
				18			22			25			35			42			50			
				VE3W -E2	VE3B -E2	VE3S -E2	VE3W -E2	VE3B -E2	VE3S -E2	VE3W -E2	VE3B -E2	VE3S -E2	VE3W -E2	VE3B -E2	VE3S -E2	VE3W -E2	VE3B -E2	VE3S -E2	VE3W -E2	VE3B -E2	VE3S -E2	
12	E22 R80 426	REMOTE CONTROLLER		1	1	1	1	1	1	1	1	1	1	1	1	1	1	1	1	1	1	SG15D
13	E22 F28 083	REMOTE CONTROLLER HOLDER		1	1	1	1	1	1	1	1	1	1	1	1	1	1	1	1	1	1	

MSZ-EF18VE3W -E2 MSZ-EF22VE3W -E2 MSZ-EF25VE3W -E2
MSZ-EF18VE3B -E2 MSZ-EF22VE3B -E2 MSZ-EF25VE3B -E2
MSZ-EF18VE3S -E2 MSZ-EF22VE3S -E2 MSZ-EF25VE3S -E2
MSZ-EF35VE3W -E2 MSZ-EF42VE3W -E2 MSZ-EF50VE3W -E2
MSZ-EF35VE3B -E2 MSZ-EF42VE3B -E2 MSZ-EF50VE3B -E2
MSZ-EF35VE3S -E2 MSZ-EF42VE3S -E2 MSZ-EF50VE3S -E2

1-22. INDOOR UNIT ELECTRICAL PARTS AND FUNCTIONAL PARTS

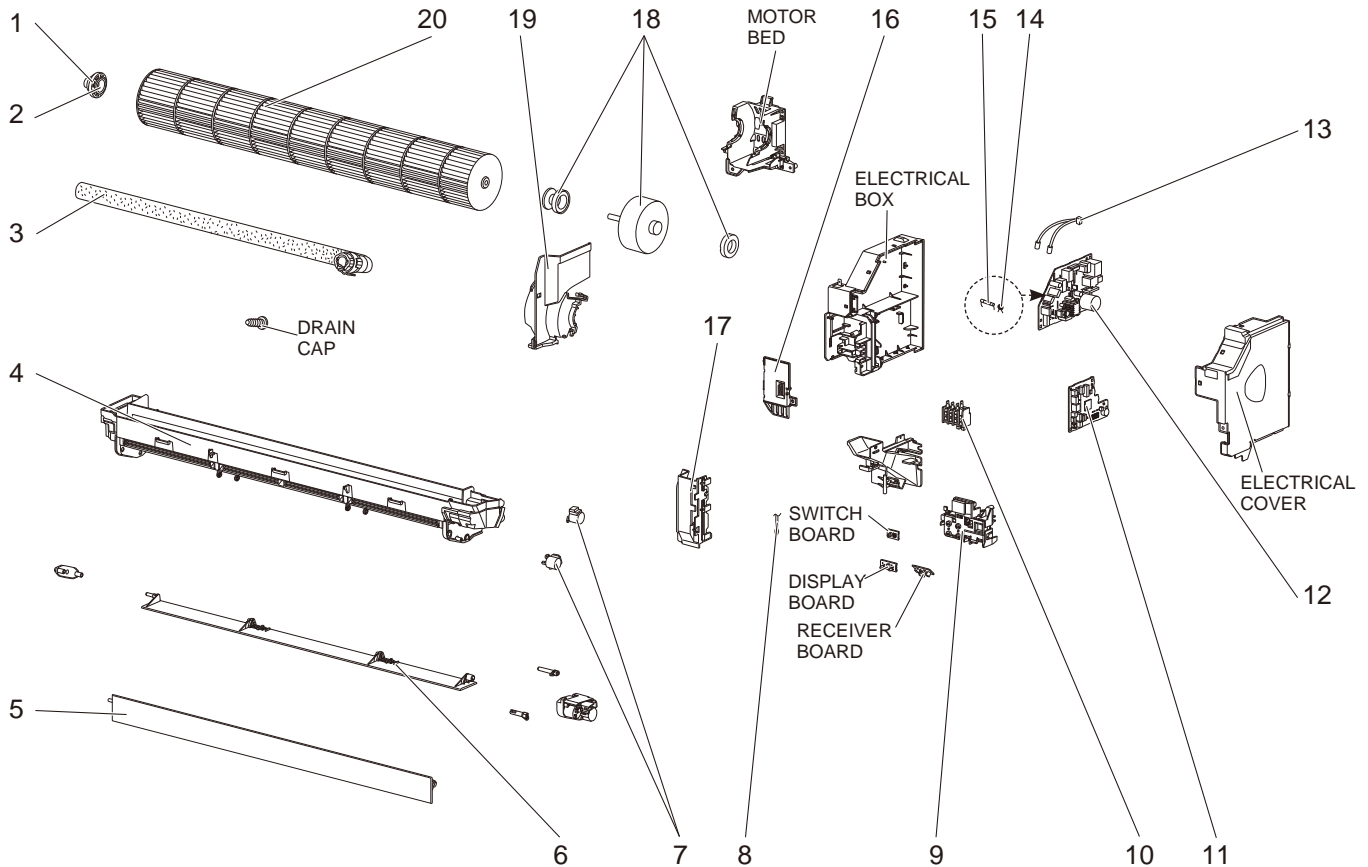

1-23. INDOOR UNIT HEAT EXCHANGER

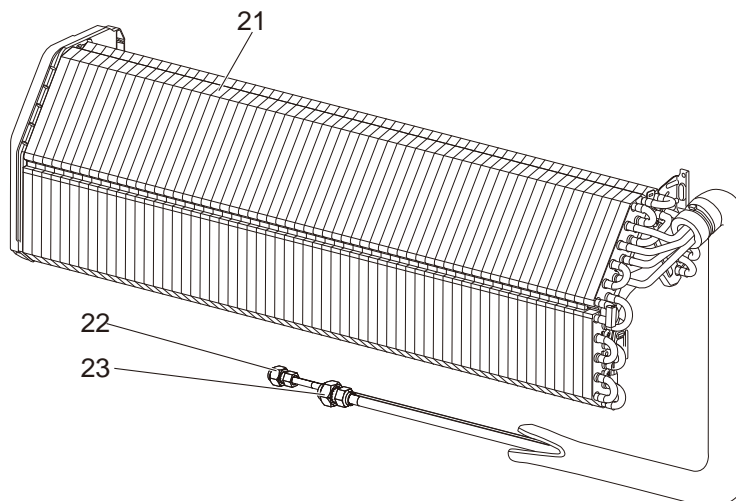

1-22. INDOOR UNIT ELECTRICAL PARTS AND FUNCTIONAL PARTS

No.	Part No.	Part name	Symbol in Wiring Diagram	Q'ty/unit															Remarks				
				MSZ-EF																			
				18			22			25			35			42				50			
				VE3W -E2	VE3B -E2	VE3S -E2	VE3W -E2	VE3B -E2	VE3S -E2	VE3W -E2	VE3B -E2	VE3S -E2	VE3W -E2	VE3B -E2	VE3S -E2	VE3W -E2	VE3B -E2	VE3S -E2		VE3W -E2	VE3B -E2	VE3S -E2	
1	E22 751 509	BEARING MOUNT		1	1	1	1	1	1	1	1	1	1	1	1	1	1	1	1	1			
2	E22 001 504	SLEEVE BEARING		1	1	1	1	1	1	1	1	1	1	1	1	1	1	1	1	1	1		
3	E22 P72 702	DRAIN HOSE		1	1	1	1	1	1	1	1	1	1	1	1	1	1	1	1	1	1		
4	E22 F95 235	NOZZLE ASSEMBLY		1			1			1			1			1			1				
	E22 G21 235	NOZZLE ASSEMBLY			1			1			1			1			1			1			
	E22 G26 235	NOZZLE ASSEMBLY				1			1			1			1			1			1		
5	E22 F95 040	VANE UPPER		1			1			1			1			1			1				
	E22 G21 040	VANE UPPER			1			1			1			1			1			1			
	E22 G26 040	VANE UPPER				1			1			1			1			1			1		
6	E22 F95 041	VANE LOWER		1			1			1			1			1			1				
	E22 G21 041	VANE LOWER			1			1			1			1			1			1			
	E22 G26 041	VANE LOWER				1			1			1			1			1			1		
7	E22 A89 303	VANE MOTOR	MV	2	2	2	2	2	2	2	2	2	2	2	2	2	2	2	2	2	2	UP & DOWN, 1 PC/SET	
8	E22 F95 308	ROOM TEMPERATURE THERMISTOR	RT11	1	1	1	1	1	1	1	1	1	1	1	1	1	1	1	1	1	1		
9	E22 F95 095	DISPLAY P.C. BOARD HOLDER		1	1	1	1	1	1	1	1	1	1	1	1	1	1	1	1	1	1		
10	E22 T21 375	TERMINAL BLOCK	TB	1	1	1	1	1	1	1	1	1	1	1	1	1	1	1	1	1	1		
11	E22 K14 452	ELECTRONIC CONTROL P.C. BOARD		1	1	1	1	1	1													Includes RECEIVER BOARD, DISPLAY BOARD and SWITCH BOARD.	
	E22 K15 452	ELECTRONIC CONTROL P.C. BOARD							1	1	1												
	E22 K16 452	ELECTRONIC CONTROL P.C. BOARD										1	1	1									
	E22 K17 452	ELECTRONIC CONTROL P.C. BOARD													1	1	1						
	E22 K18 452	ELECTRONIC CONTROL P.C. BOARD																	1	1	1		
12	E22 F98 440	POWER P.C. BOARD		1	1	1	1	1	1	1	1	1	1	1	1	1	1	1	1	1	1		
13	E22 F95 307	INDOOR COIL THERMISTOR	RT12,RT13	1	1	1	1	1	1	1	1	1	1	1	1	1	1	1	1	1	1		
14	E22 B75 385	VARISTOR	NR11	1	1	1	1	1	1	1	1	1	1	1	1	1	1	1	1	1	1		
15	E22 A49 382	FUSE	F11	1	1	1	1	1	1	1	1	1	1	1	1	1	1	1	1	1	1	T3.15AL250V	
16	E22 F95 784	V.A. CLAMP		1	1	1	1	1	1	1	1	1	1	1	1	1	1	1	1	1	1		
17	E22 F95 541	WATER CUT		1	1	1	1	1	1	1	1	1	1	1	1	1	1	1	1	1	1		
18	E22 J44 300	INDOOR FAN MOTOR	MF	1	1	1	1	1	1	1	1	1	1	1	1	1	1	1	1	1	1	RC0J40-□□ Includes FAN MOTOR RUBBER MOUNT (2 PCS/SET)	
19	E22 F95 333	MOTOR BAND		1	1	1	1	1	1	1	1	1	1	1	1	1	1	1	1	1	1		
20	E22 F95 302	LINE FLOW FAN		1	1	1	1	1	1	1	1	1	1	1	1	1	1	1	1	1	1		

1-23. INDOOR UNIT HEAT EXCHANGER

No.	Part No.	Part name	Symbol in Wiring Diagram	Q'ty/unit															Remarks			
				MSZ-EF																		
				18			22			25			35			42				50		
				VE3W -E2	VE3B -E2	VE3S -E2	VE3W -E2	VE3B -E2	VE3S -E2	VE3W -E2	VE3B -E2	VE3S -E2	VE3W -E2	VE3B -E2	VE3S -E2	VE3W -E2	VE3B -E2	VE3S -E2		VE3W -E2	VE3B -E2	VE3S -E2
21	E22 F95 620	INDOOR HEAT EXCHANGER		1	1	1	1	1	1	1	1	1	1	1	1	1	1	1	1	1	1	
	E22 F99 620	INDOOR HEAT EXCHANGER																	1	1	1	
22	E22 151 667	UNION (LIQUID)		1	1	1	1	1	1	1	1	1	1	1	1	1	1	1	1	1	1	ø6.35
23	E22 815 666	UNION (GAS)		1	1	1	1	1	1	1	1	1	1	1	1	1	1	1	1	1	1	ø9.52
	E22 155 666	UNION (GAS)																	1	1	1	ø12.7

MSZ-EF22VE3W -ER1 MSZ-EF25VE3W -ER1 MSZ-EF35VE3W -ER1
MSZ-EF22VE3B -ER1 MSZ-EF25VE3B -ER1 MSZ-EF35VE3B -ER1
MSZ-EF22VE3S -ER1 MSZ-EF25VE3S -ER1 MSZ-EF35VE3S -ER1
MSZ-EF42VE3W -ER1 MSZ-EF50VE3W -ER1
MSZ-EF42VE3B -ER1 MSZ-EF50VE3B -ER1
MSZ-EF42VE3S -ER1 MSZ-EF50VE3S -ER1

1-24. INDOOR UNIT STRUCTURAL PARTS

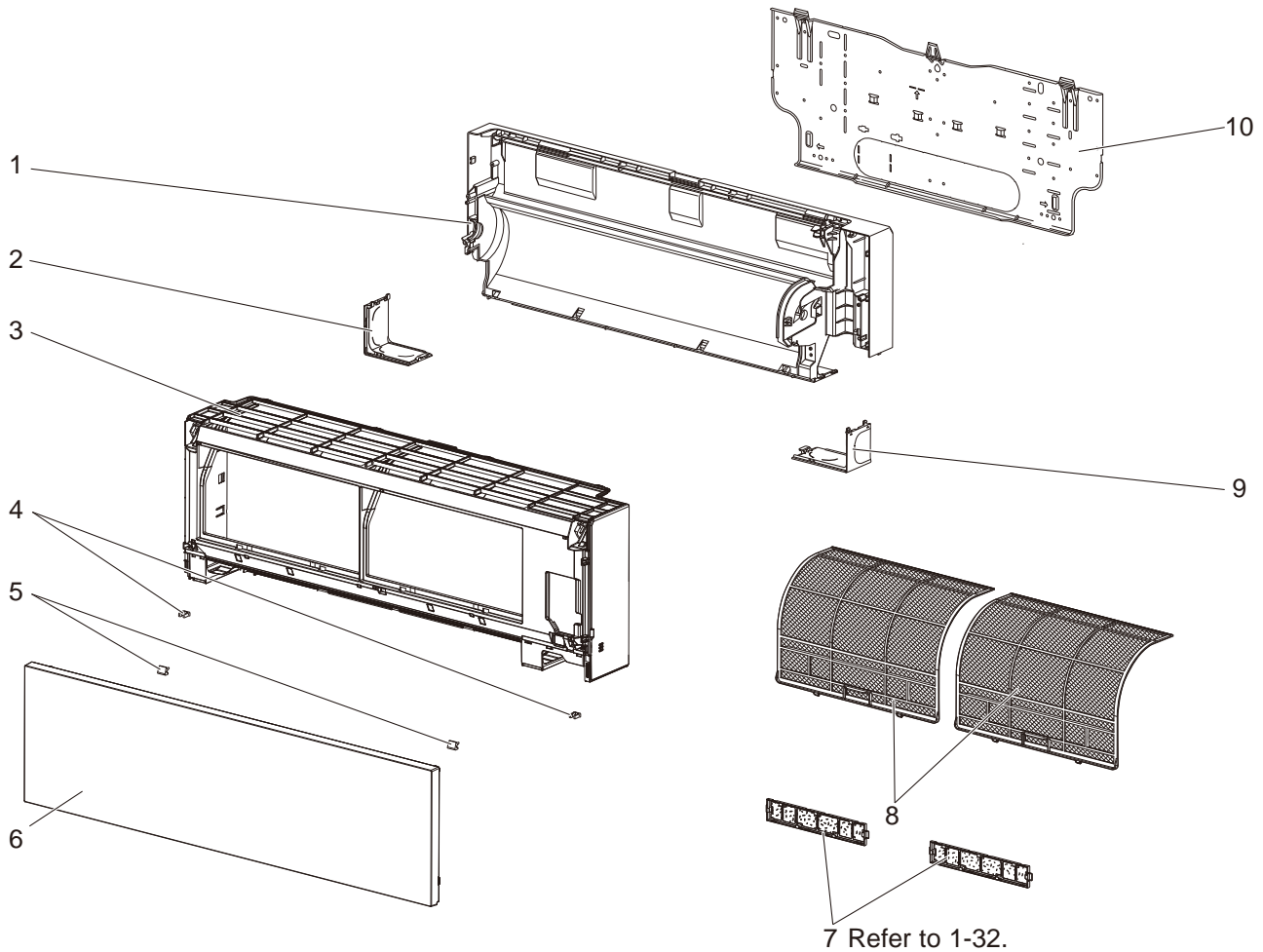

1-25. ACCESSORY AND REMOTE CONTROLLER

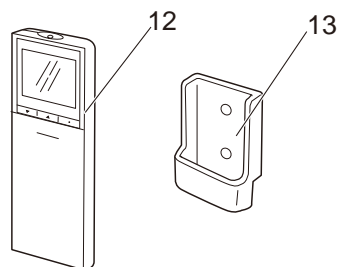

1-24. INDOOR UNIT STRUCTURAL PARTS

Part numbers that is circled is not shown in the illustration.

No.	Part No.	Part name	Symbol in Wiring Diagram	Q'ty/unit															Remarks	
				MSZ-EF																
				22			25			35			42			50				
				VE3W -ER1	VE3B -ER1	VE3S -ER1	VE3W -ER1	VE3B -ER1	VE3S -ER1	VE3W -ER1	VE3B -ER1	VE3S -ER1	VE3W -ER1	VE3B -ER1	VE3S -ER1	VE3W -ER1	VE3B -ER1	VE3S -ER1		
1	E12 F95 234	BOX ASSEMBLY		1			1			1			1			1				
	E12 G21 234	BOX ASSEMBLY			1		1			1			1			1				
	E12 G26 234	BOX ASSEMBLY				1		1			1			1			1			
2	E12 F95 976	CORNER BOX LEFT		1			1			1			1			1				
	E12 G21 976	CORNER BOX LEFT			1		1			1			1			1				
	E12 G26 976	CORNER BOX LEFT				1		1			1			1		1				
3	E12 W32 000	PANEL ASSEMBLY		1			1			1			1			1			Includes No. 4, 5, and 6	
	E12 W44 000	PANEL ASSEMBLY			1		1			1			1			1			Includes No. 4, 5, and 6	
	E12 W38 000	PANEL ASSEMBLY				1		1			1			1			1		Includes No. 4, 5, and 6	
4	E12 F95 142	CATCH		2	2	2	2	2	2	2	2	2	2	2	2	2	2	2	2	2 PCS/SET
5	E12 F95 067	SCREW CAP		2			2			2			2			2			2	2 PCS/SET
	E12 G21 067	SCREW CAP			2		2			2			2			2			2	2 PCS/SET
	E12 G26 067	SCREW CAP				2		2			2			2			2		2	2 PCS/SET
6	E12 T21 010	FRONT PANEL		1			1			1			1			1				
	E12 T25 010	FRONT PANEL			1		1			1			1			1				
	E12 T29 010	FRONT PANEL				1		1			1			1			1			
7	—	AIR CLEANING FILTER (SILVER-IONIZED AIR PURIFIER FILTER)		2	2	2	2	2	2	2	2	2	2	2	2	2	2	2	2	1 PC/SET
8	E12 W14 100	AIR FILTER (AIR PURIFYING FILTER)		2	2	2	2	2	2	2	2	2	2	2	2	2	2	2	2	1 PC/SET
9	E12 F95 975	CORNER BOX RIGHT		1			1			1			1			1				
	E12 G21 975	CORNER BOX RIGHT			1		1			1			1			1				
	E12 G26 975	CORNER BOX RIGHT				1		1			1			1			1			
10	E12 F95 970	INSTALLATION PLATE		1	1	1	1	1	1	1	1	1	1	1	1	1	1	1	1	
⑪	—	SOFT DRY CLOTH			1		1			1			1			1				MAC-1001CL-E

1-25. ACCESSORY AND REMOTE CONTROLLER

No.	Part No.	Part name	Symbol in Wiring Diagram	Q'ty/unit															Remarks		
				MSZ-EF																	
				22			25			35			42			50					
				VE3W -ER1	VE3B -ER1	VE3S -ER1	VE3W -ER1	VE3B -ER1	VE3S -ER1	VE3W -ER1	VE3B -ER1	VE3S -ER1	VE3W -ER1	VE3B -ER1	VE3S -ER1	VE3W -ER1	VE3B -ER1	VE3S -ER1			
12	E12 R80 426	REMOTE CONTROLLER		1	1	1	1	1	1	1	1	1	1	1	1	1	1	1	1	1	SG15D
13	E12 F28 083	REMOTE CONTROLLER HOLDER		1	1	1	1	1	1	1	1	1	1	1	1	1	1	1	1	1	

MSZ-EF22VE3W -[ER1] MSZ-EF25VE3W -[ER1] MSZ-EF35VE3W -[ER1]

MSZ-EF22VE3B -[ER1] MSZ-EF25VE3B -[ER1] MSZ-EF35VE3B -[ER1]

MSZ-EF22VE3S -[ER1] MSZ-EF25VE3S -[ER1] MSZ-EF35VE3S -[ER1]

MSZ-EF42VE3W -[ER1] MSZ-EF50VE3W -[ER1]

MSZ-EF42VE3B -[ER1] MSZ-EF50VE3B -[ER1]

MSZ-EF42VE3S -[ER1] MSZ-EF50VE3S -[ER1]

1-26. INDOOR UNIT ELECTRICAL PARTS AND FUNCTIONAL PARTS

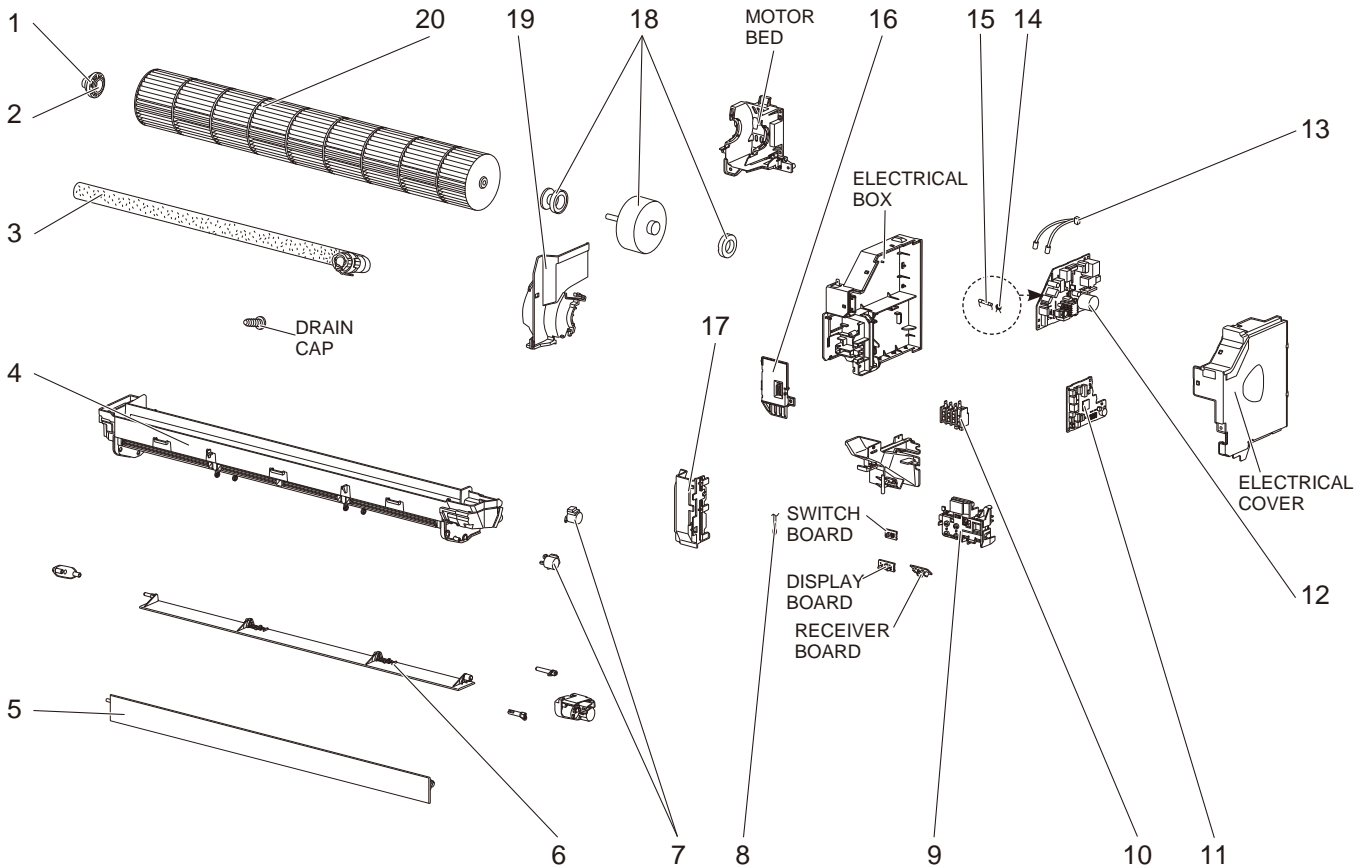

1-27. INDOOR UNIT HEAT EXCHANGER

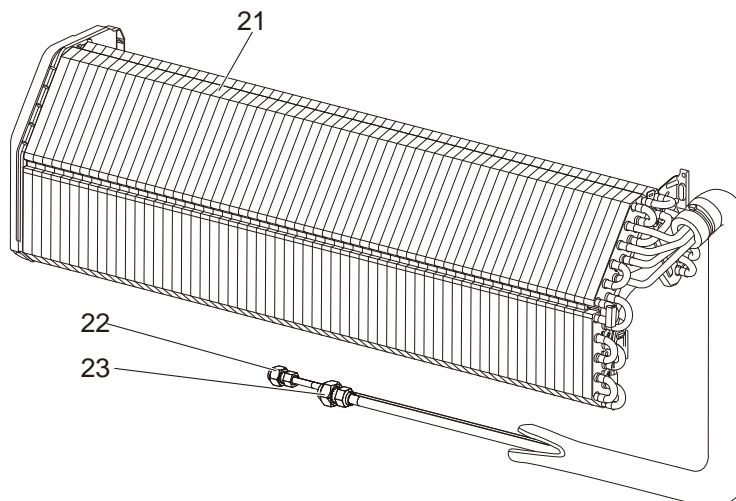

1-26. INDOOR UNIT ELECTRICAL PARTS AND FUNCTIONAL PARTS

No.	Part No.	Part name	Symbol in Wiring Diagram	Q'ty/unit												Remarks			
				MSZ-EF															
				22			25			35			42				50		
				VE3W -ER1	VE3B -ER1	VE3S -ER1	VE3W -ER1	VE3B -ER1	VE3S -ER1	VE3W -ER1	VE3B -ER1	VE3S -ER1	VE3W -ER1	VE3B -ER1	VE3S -ER1		VE3W -ER1	VE3B -ER1	VE3S -ER1
1	E12 751 509	BEARING MOUNT		1	1	1	1	1	1	1	1	1	1	1	1	1	1	1	
2	E12 001 504	SLEEVE BEARING		1	1	1	1	1	1	1	1	1	1	1	1	1	1	1	
3	E12 897 702	DRAIN HOSE		1	1	1	1	1	1	1	1	1	1	1	1	1	1	1	
4	E12 F95 235	NOZZLE ASSEMBLY		1			1			1			1			1			
	E12 G21 235	NOZZLE ASSEMBLY			1			1			1			1			1		
	E12 G26 235	NOZZLE ASSEMBLY				1			1			1			1			1	
5	E12 F95 040	VANE UPPER		1			1			1			1			1			
	E12 G21 040	VANE UPPER			1			1			1			1			1		
	E12 G26 040	VANE UPPER				1			1			1			1			1	
6	E12 F95 041	VANE LOWER		1			1			1			1			1			
	E12 G21 041	VANE LOWER			1			1			1			1			1		
	E12 G26 041	VANE LOWER				1			1			1			1			1	
7	E12 A89 303	VANE MOTOR	MV	2	2	2	2	2	2	2	2	2	2	2	2	2	2	2	UP & DOWN, 1 PC/SET
8	E12 F95 308	ROOM TEMPERATURE THERMISTOR	RT11	1	1	1	1	1	1	1	1	1	1	1	1	1	1	1	
9	E12 F95 095	DISPLAY P.C. BOARD HOLDER		1	1	1	1	1	1	1	1	1	1	1	1	1	1	1	
10	E12 T21 375	TERMINAL BLOCK	TB	1	1	1	1	1	1	1	1	1	1	1	1	1	1	1	
11	E12 K14 452	ELECTRONIC CONTROL P.C. BOARD		1	1	1													Includes RECEIVER BOARD, DISPLAY BOARD and SWITCH BOARD.
	E12 K15 452	ELECTRONIC CONTROL P.C. BOARD					1	1	1										
	E12 K16 452	ELECTRONIC CONTROL P.C. BOARD								1	1	1							
	E12 K17 452	ELECTRONIC CONTROL P.C. BOARD											1	1	1				
	E12 K18 452	ELECTRONIC CONTROL P.C. BOARD														1	1	1	
12	E12 F98 440	POWER P.C. BOARD		1	1	1	1	1	1	1	1	1	1	1	1	1	1	1	
13	E12 F95 307	INDOOR COIL THERMISTOR	RT12,RT13	1	1	1	1	1	1	1	1	1	1	1	1	1	1	1	
14	E12 B75 385	VARIATOR	NR11	1	1	1	1	1	1	1	1	1	1	1	1	1	1	1	
15	E12 A49 382	FUSE	F11	1	1	1	1	1	1	1	1	1	1	1	1	1	1	1	T3.15AL250V
16	E12 F95 784	V.A. CLAMP		1	1	1	1	1	1	1	1	1	1	1	1	1	1	1	
17	E12 F95 541	WATER CUT		1	1	1	1	1	1	1	1	1	1	1	1	1	1	1	
18	E12 J44 300	INDOOR FAN MOTOR	MF	1	1	1	1	1	1	1	1	1	1	1	1	1	1	1	RC0J40-□□ Includes FAN MOTOR RUBBER MOUNT (2 PCS/SET)
19	E12 F95 333	MOTOR BAND		1	1	1	1	1	1	1	1	1	1	1	1	1	1	1	
20	E12 F95 302	LINE FLOW FAN		1	1	1	1	1	1	1	1	1	1	1	1	1	1	1	

1-27. INDOOR UNIT HEAT EXCHANGER

No.	Part No.	Part name	Symbol in Wiring Diagram	Q'ty/unit												Remarks			
				MSZ-EF															
				22			25			35			42				50		
				VE3W -ER1	VE3B -ER1	VE3S -ER1	VE3W -ER1	VE3B -ER1	VE3S -ER1	VE3W -ER1	VE3B -ER1	VE3S -ER1	VE3W -ER1	VE3B -ER1	VE3S -ER1		VE3W -ER1	VE3B -ER1	VE3S -ER1
21	E12 F95 620	INDOOR HEAT EXCHANGER		1	1	1	1	1	1	1	1	1	1	1	1				
	E12 F99 620	INDOOR HEAT EXCHANGER														1	1	1	
22	E12 151 667	UNION (LIQUID)		1	1	1	1	1	1	1	1	1	1	1	1	1	1	1	ø6.35
23	E12 815 666	UNION (GAS)		1	1	1	1	1	1	1	1	1	1	1	1				ø9.52
	E12 155 666	UNION (GAS)														1	1	1	ø12.7

MSZ-EF22VE3W -ER2 MSZ-EF25VE3W -ER2 MSZ-EF35VE3W -ER2
MSZ-EF22VE3B -ER2 MSZ-EF25VE3B -ER2 MSZ-EF35VE3B -ER2
MSZ-EF22VE3S -ER2 MSZ-EF25VE3S -ER2 MSZ-EF35VE3S -ER2
MSZ-EF42VE3W -ER2 MSZ-EF50VE3W -ER2
MSZ-EF42VE3B -ER2 MSZ-EF50VE3B -ER2
MSZ-EF42VE3S -ER2 MSZ-EF50VE3S -ER2

1-28. INDOOR UNIT STRUCTURAL PARTS

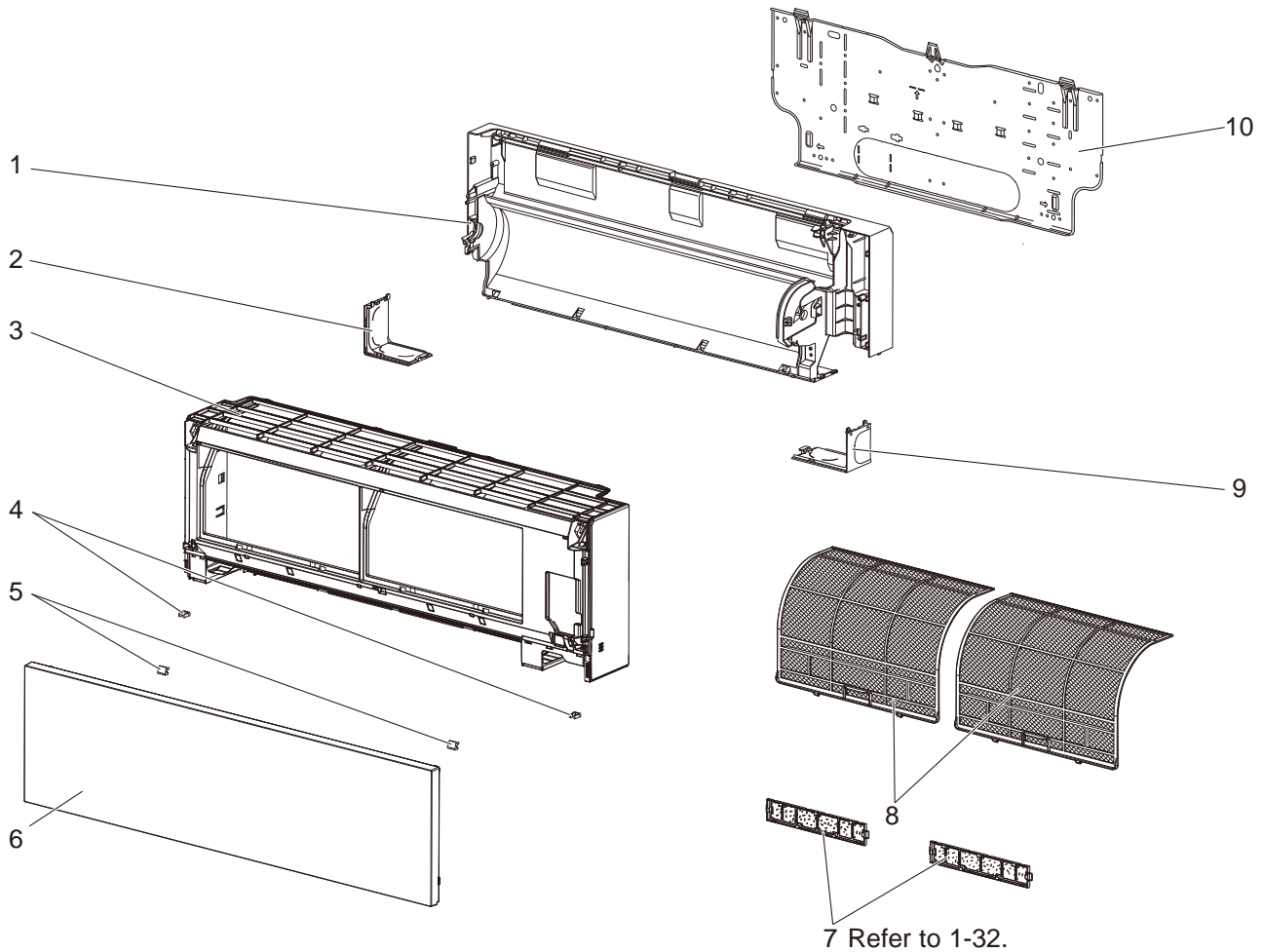

1-29. ACCESSORY AND REMOTE CONTROLLER

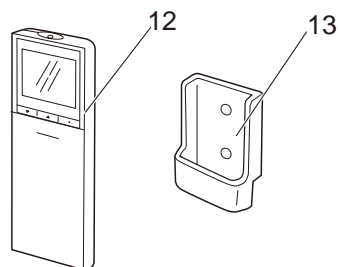

1-28. INDOOR UNIT STRUCTURAL PARTS

Part numbers that is circled is not shown in the illustration.

No.	Part No.	Part name	Symbol in Wiring Diagram	Q'ty/unit															Remarks
				MSZ-EF															
				22			25			35			42			50			
				VE3W -ER2	VE3B -ER2	VE3S -ER2	VE3W -ER2	VE3B -ER2	VE3S -ER2	VE3W -ER2	VE3B -ER2	VE3S -ER2	VE3W -ER2	VE3B -ER2	VE3S -ER2	VE3W -ER2	VE3B -ER2	VE3S -ER2	
1	E22 F95 234	BOX ASSEMBLY		1			1			1			1			1			
	E22 G21 234	BOX ASSEMBLY			1		1			1			1			1			
	E22 G26 234	BOX ASSEMBLY				1			1			1			1			1	
2	E22 F95 976	CORNER BOX LEFT		1			1			1			1			1			
	E22 G21 976	CORNER BOX LEFT			1		1			1			1			1			
	E22 G26 976	CORNER BOX LEFT				1			1			1			1			1	
3	E22 W32 000	PANEL ASSEMBLY		1			1			1			1			1			Includes No. 4, 5, and 6
	E22 W44 000	PANEL ASSEMBLY			1		1			1			1			1			Includes No. 4, 5, and 6
	E22 W38 000	PANEL ASSEMBLY				1			1			1			1			1	Includes No. 4, 5, and 6
4	E22 F95 142	CATCH		2	2	2	2	2	2	2	2	2	2	2	2	2	2	2	2 PCS/SET
5	E22 F95 067	SCREW CAP		2			2			2			2			2			2 PCS/SET
	E22 G21 067	SCREW CAP			2			2			2			2			2		2 PCS/SET
	E22 G26 067	SCREW CAP				2			2			2			2			2	2 PCS/SET
6	E22 T21 010	FRONT PANEL		1			1			1			1			1			
	E22 T25 010	FRONT PANEL			1			1			1			1			1		
	E22 T29 010	FRONT PANEL				1			1			1			1			1	
7	—	AIR CLEANING FILTER (SILVER-JONIZED AIR PURIFIER FILTER)		2	2	2	2	2	2	2	2	2	2	2	2	2	2	2	1 PC/SET
8	E22 W14 100	AIR FILTER (AIR PURIFYING FILTER)		2	2	2	2	2	2	2	2	2	2	2	2	2	2	2	1 PC/SET
9	E22 F95 975	CORNER BOX RIGHT		1			1			1			1			1			
	E22 G21 975	CORNER BOX RIGHT			1			1			1			1			1		
	E22 G26 975	CORNER BOX RIGHT				1			1			1			1			1	
10	E22 F95 970	INSTALLATION PLATE		1	1	1	1	1	1	1	1	1	1	1	1	1	1	1	
⑪	—	SOFT DRY CLOTH			1			1			1			1			1		MAC-1001CL-E

1-29. ACCESSORY AND REMOTE CONTROLLER

No.	Part No.	Part name	Symbol in Wiring Diagram	Q'ty/unit															Remarks
				MSZ-EF															
				22			25			35			42			50			
				VE3W -ER2	VE3B -ER2	VE3S -ER2	VE3W -ER2	VE3B -ER2	VE3S -ER2	VE3W -ER2	VE3B -ER2	VE3S -ER2	VE3W -ER2	VE3B -ER2	VE3S -ER2	VE3W -ER2	VE3B -ER2	VE3S -ER2	
12	E22 R80 426	REMOTE CONTROLLER		1	1	1	1	1	1	1	1	1	1	1	1	1	1	1	SG15D
13	E22 F28 083	REMOTE CONTROLLER HOLDER		1	1	1	1	1	1	1	1	1	1	1	1	1	1	1	

MSZ-EF22VE3W -ER2 MSZ-EF25VE3W -ER2 MSZ-EF35VE3W -ER2

MSZ-EF22VE3B -ER2 MSZ-EF25VE3B -ER2 MSZ-EF35VE3B -ER2

MSZ-EF22VE3S -ER2 MSZ-EF25VE3S -ER2 MSZ-EF35VE3S -ER2

MSZ-EF42VE3W -ER2 MSZ-EF50VE3W -ER2

MSZ-EF42VE3B -ER2 MSZ-EF50VE3B -ER2

MSZ-EF42VE3S -ER2 MSZ-EF50VE3S -ER2

1-30. INDOOR UNIT ELECTRICAL PARTS AND FUNCTIONAL PARTS

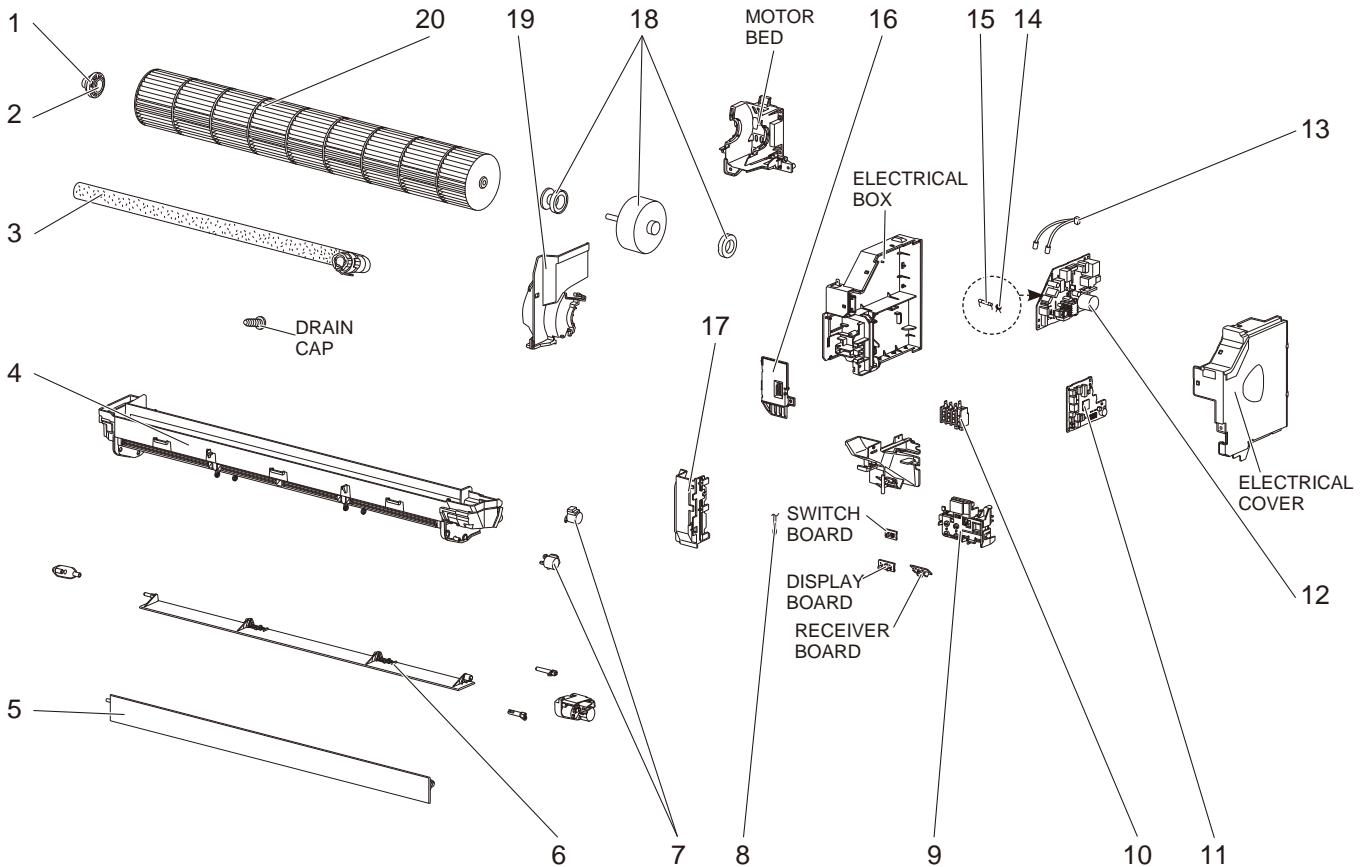

1-31. INDOOR UNIT HEAT EXCHANGER

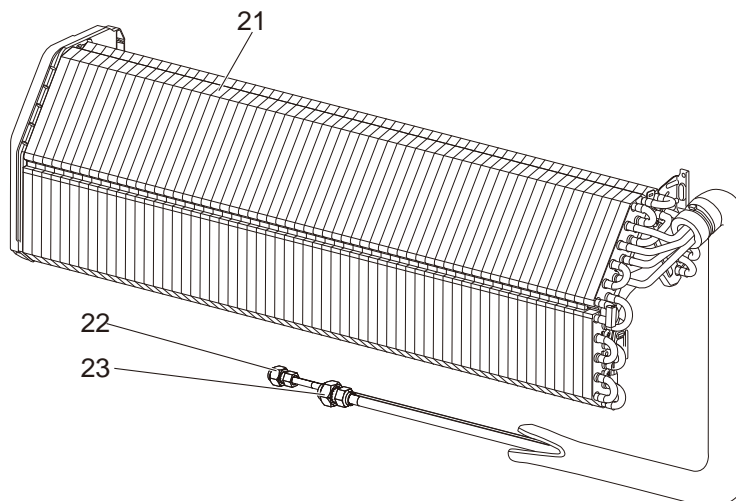

1-30. INDOOR UNIT ELECTRICAL PARTS AND FUNCTIONAL PARTS

No.	Part No.	Part name	Symbol in Wiring Diagram	Q'ty/unit															Remarks
				MSZ-EF															
				22			25			35			42			50			
VE3W	VE3B	VE3S	VE3W	VE3B	VE3S	VE3W	VE3B	VE3S	VE3W	VE3B	VE3S	VE3W	VE3B	VE3S	VE3W	VE3B	VE3S		
	-ER2	-ER2	-ER2	-ER2	-ER2	-ER2	-ER2	-ER2	-ER2	-ER2	-ER2	-ER2	-ER2	-ER2	-ER2	-ER2	-ER2	-ER2	
1	E22 751 509	BEARING MOUNT		1	1	1	1	1	1	1	1	1	1	1	1	1	1	1	
2	E22 001 504	SLEEVE BEARING		1	1	1	1	1	1	1	1	1	1	1	1	1	1	1	
3	E22 P72 702	DRAIN HOSE		1	1	1	1	1	1	1	1	1	1	1	1	1	1	1	
4	E22 F95 235	NOZZLE ASSEMBLY		1			1			1			1			1			
	E22 G21 235	NOZZLE ASSEMBLY			1			1			1			1			1		
	E22 G26 235	NOZZLE ASSEMBLY				1			1			1			1			1	
5	E22 F95 040	VANE UPPER		1			1			1			1			1			
	E22 G21 040	VANE UPPER			1			1			1			1			1		
	E22 G26 040	VANE UPPER				1			1			1			1			1	
6	E22 F95 041	VANE LOWER		1			1			1			1			1			
	E22 G21 041	VANE LOWER			1			1			1			1			1		
	E22 G26 041	VANE LOWER				1			1			1			1			1	
7	E22 A89 303	VANE MOTOR	MV	2	2	2	2	2	2	2	2	2	2	2	2	2	2	2	
8	E22 F95 308	ROOM TEMPERATURE THERMISTOR	RT11	1	1	1	1	1	1	1	1	1	1	1	1	1	1	1	
9	E22 F95 095	DISPLAY P.C. BOARD HOLDER		1	1	1	1	1	1	1	1	1	1	1	1	1	1	1	
10	E22 T21 375	TERMINAL BLOCK	TB	1	1	1	1	1	1	1	1	1	1	1	1	1	1	1	
11	E22 K14 452	ELECTRONIC CONTROL P.C. BOARD		1	1	1													
	E22 K15 452	ELECTRONIC CONTROL P.C. BOARD					1	1	1										
	E22 K16 452	ELECTRONIC CONTROL P.C. BOARD								1	1	1							
	E22 K17 452	ELECTRONIC CONTROL P.C. BOARD											1	1	1				
	E22 K18 452	ELECTRONIC CONTROL P.C. BOARD														1	1	1	
12	E22 F98 440	POWER P.C. BOARD		1	1	1	1	1	1	1	1	1	1	1	1	1	1	1	
13	E22 F95 307	INDOOR COIL THERMISTOR	RT12,RT13	1	1	1	1	1	1	1	1	1	1	1	1	1	1	1	
14	E22 B75 385	VARISTOR	NR11	1	1	1	1	1	1	1	1	1	1	1	1	1	1	1	
15	E22 A49 382	FUSE	F11	1	1	1	1	1	1	1	1	1	1	1	1	1	1	1	
16	E22 F95 784	V.A. CLAMP		1	1	1	1	1	1	1	1	1	1	1	1	1	1	1	
17	E22 F95 541	WATER CUT		1	1	1	1	1	1	1	1	1	1	1	1	1	1	1	
18	E22 J44 300	INDOOR FAN MOTOR	MF	1	1	1	1	1	1	1	1	1	1	1	1	1	1	1	
19	E22 F95 333	MOTOR BAND		1	1	1	1	1	1	1	1	1	1	1	1	1	1	1	
20	E22 F95 302	LINE FLOW FAN		1	1	1	1	1	1	1	1	1	1	1	1	1	1	1	

1-31. INDOOR UNIT HEAT EXCHANGER

No.	Part No.	Part name	Symbol in Wiring Diagram	Q'ty/unit															Remarks
				MSZ-EF															
				22			25			35			42			50			
VE3W	VE3B	VE3S	VE3W	VE3B	VE3S	VE3W	VE3B	VE3S	VE3W	VE3B	VE3S	VE3W	VE3B	VE3S	VE3W	VE3B	VE3S		
	-ER2	-ER2	-ER2	-ER2	-ER2	-ER2	-ER2	-ER2	-ER2	-ER2	-ER2	-ER2	-ER2	-ER2	-ER2	-ER2	-ER2	-ER2	
21	E22 F95 620	INDOOR HEAT EXCHANGER		1	1	1	1	1	1	1	1	1	1	1	1				
	E22 F99 620	INDOOR HEAT EXCHANGER													1	1	1		
22	E22 151 667	UNION (LIQUID)		1	1	1	1	1	1	1	1	1	1	1	1	1	1	1	
23	E22 815 666	UNION (GAS)		1	1	1	1	1	1	1	1	1	1	1				ø6.35	
	E22 155 666	UNION (GAS)													1	1	1	ø9.52	
																		ø12.7	

1-32. AIR CLEANING FILTER (Silver-ionized air purifier filter)

Every 3 months:

- Remove dirt by a vacuum cleaner.

When dirt cannot be removed by vacuum cleaning:

- Soak the filter and its frame in lukewarm water before rinsing it.
- After washing, dry it well in shade. Install all tabs of the air filter.

Every year:

- Replace it with a new air cleaning filter for best performance.

NOTE 1: Clean the filters regularly for best performance and to reduce power consumption.

NOTE 2: Dirty filters cause condensation in the air conditioner which will contribute to the growth of fungi such as mold.
It is therefore recommended to clean air filters every 2 weeks.

Model		Part No.
MSZ-EF18VE3W	MSZ-EF35VE3W	MAC-2370FT-E
MSZ-EF18VE3B	MSZ-EF35VE3B	
MSZ-EF18VE3S	MSZ-EF35VE3S	
MSZ-EF22VE3W	MSZ-EF42VE3W	
MSZ-EF22VE3B	MSZ-EF42VE3B	
MSZ-EF22VE3S	MSZ-EF42VE3S	
MSZ-EF25VE3W	MSZ-EF50VE3W	
MSZ-EF25VE3B	MSZ-EF50VE3B	
MSZ-EF25VE3S	MSZ-EF50VE3S	

2-1. AIR CLEANING FILTER

ELECTROSTATIC ANTI-ALLERGY ENZYME FILTER

Every 3 months:

- Remove dirt by a vacuum cleaner.

When dirt cannot be removed by vacuum cleaning:

- Soak the filter and its frame in lukewarm water before rinsing it.
- After washing, dry it well in shade. Install all tabs of the air filter.

Every year:

- Replace it with a new air cleaning filter for best performance.

NOTE 1: Clean the filters regularly for best performance and to reduce power consumption.

NOTE 2: Dirty filters cause condensation in the air conditioner which will contribute to the growth of fungi such as mold. It is therefore recommended to clean air filters every 2 weeks.

Model		Part No.
MSZ-EF18VEW	MSZ-EF18VE2W	MAC-2320FT
MSZ-EF18VEB	MSZ-EF18VE2B	
MSZ-EF18VES	MSZ-EF18VE2S	
MSZ-EF22VEW	MSZ-EF22VE2W	
MSZ-EF22VEB	MSZ-EF22VE2B	
MSZ-EF22VES	MSZ-EF22VE2S	
MSZ-EF25VEW	MSZ-EF25VE2W	
MSZ-EF25VEB	MSZ-EF25VE2B	
MSZ-EF25VES	MSZ-EF25VE2S	
MSZ-EF35VEW	MSZ-EF35VE2W	
MSZ-EF35VEB	MSZ-EF35VE2B	
MSZ-EF35VES	MSZ-EF35VE2S	
MSZ-EF42VEW	MSZ-EF42VE2W	
MSZ-EF42VEB	MSZ-EF42VE2B	
MSZ-EF42VES	MSZ-EF42VE2S	
MSZ-EF50VEW	MSZ-EF50VE2W	
MSZ-EF50VEB	MSZ-EF50VE2B	
MSZ-EF50VES	MSZ-EF50VE2S	

Pull to remove from the air filter

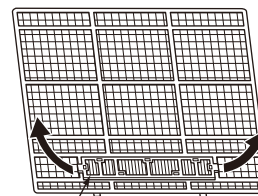

Air cleaning filter
(Electrostatic anti-allergy enzyme filter)

2-2. SOFT DRY CLOTH

- Clean the panel with the soft dry cloth when it is dirty.

Model			Part No.
MSZ-EF18VEW	MSZ-EF18VE2W	MSZ-EF18VE3W	MAC-1001CL-E
MSZ-EF18VES	MSZ-EF18VE2S	MSZ-EF18VE3S	
MSZ-EF22VEW	MSZ-EF22VE2W	MSZ-EF22VE3W	
MSZ-EF22VES	MSZ-EF22VE2S	MSZ-EF22VE3S	
MSZ-EF25VEW	MSZ-EF25VE2W	MSZ-EF25VE3W	
MSZ-EF25VES	MSZ-EF25VE2S	MSZ-EF25VE3S	
MSZ-EF35VEW	MSZ-EF35VE2W	MSZ-EF35VE3W	
MSZ-EF35VES	MSZ-EF35VE2S	MSZ-EF35VE3S	
MSZ-EF42VEW	MSZ-EF42VE2W	MSZ-EF42VE3W	
MSZ-EF42VES	MSZ-EF42VE2S	MSZ-EF42VE3S	
MSZ-EF50VEW	MSZ-EF50VE2W	MSZ-EF50VE3W	
MSZ-EF50VES	MSZ-EF50VE2S	MSZ-EF50VE3S	

MITSUBISHI ELECTRIC CORPORATION

HEAD OFFICE: TOKYO BUILDING, 2-7-3, MARUNOUCHI, CHIYODA-KU, TOKYO 100-8310, JAPAN

© Copyright 2010 MITSUBISHI ELECTRIC CORPORATION

Issued: Mar. 2020. No.OBB589 REVISED EDITION-F

Issued: Dec. 2017. No.OBB589 REVISED EDITION-E

Issued: Dec. 2015. No.OBB589 REVISED EDITION-D

Issued: Jan. 2014. No.OBB589 REVISED EDITION-C

Issued: Nov. 2012. No.OBB589 REVISED EDITION-B

Issued: Apr. 2012. No.OBB589 REVISED EDITION-A

Published: Nov. 2010. No. OBB589

Made in Japan

Specifications are subject to change without notice.